

MCD 3000 Softstarter

MCD 3000

Service Manual



**Section 1.0**

■ <b>Warnings</b> .....	3
-------------------------	---

**■ Spare Parts**

1.1 Main Control Module .....	4
1.2 Identity Module (Line Connection) .....	5
1.3 Identity Module (Inside Delta Connection) .....	6
1.4 Snubber/Overvoltage Protection Module .....	7
1.5 SCRs / Power Assemblies .....	9
1.6 Cooling Fans .....	12
1.7 Power Transformers .....	13

**Section 2.0**
**■ Tests**

2.1 Start Performance Test .....	15
2.2 Run Performance Test .....	15
2.3 Power Circuit Test .....	15
2.4 Control Input Test .....	16
2.5 Power Transformer Test .....	16

**Section 3.0**
**■ Component Replacement Procedures**

3.1 Main Control Module	
3007~3132 .....	17
3185~3800 .....	17
3.2 Identity Module	
3007~3132 .....	18
3185~3800 .....	18
3.3 Snubber/Overvoltage Protection Module	
3007~3055 .....	19
3075~3132 .....	19
3185~3500 .....	20
3600~3800 .....	22
3.4 SCR / Power Assemblies	
3007~3132 .....	23
3185~3800 .....	25
3.5 Cooling Fans	
3030~3055 .....	27
3075~3110 .....	29
3132 .....	31
3185~3800 .....	33
3.6 Power Transformers	
3007~3055 .....	34
3075~3110 .....	35
3132~ .....	36
3185~3800 .....	37

**Section 4.0**
**■ Schematics**

4.1 3007~3022 T5 .....	39
4.2 3030~3055 T5 .....	40
4.3 3075~3110 T5 .....	41
4.4 3132 T5 .....	42
4.5 3185~3500 T5 .....	43
4.6 3600~3800 T5 .....	44
4.7 3007~3022 T7 .....	45



4.8	3030~3055 T7 .....	46
4.9	3075~3110 T7 .....	47
4.10	3132 T7 .....	48
4.11	3185~3500 T7 .....	49
4.12	3600~3800 T7 .....	50

**Section 5.0****■ Appendix**

5.1	Typical Causes of SCR Damage .....	51
5.2	Output Relay Compatibility .....	52
5.3	Remote Control Input Failure .....	53



The MCD3000 contains dangerous voltages when connected to line voltage. Only a competent electrician should carry out the electrical installation. Improper installation of the motor or the MCD3000 may cause equipment failure, serious injury or death. Follow this manual and National Electrical Codes (NEC<sup>®</sup>) and local safety codes.

**■ Safety regulations**

1. The soft starter must be disconnected from the mains if repair work is to be carried out.
2. The [STOP] on the control panel of the soft starter does not disconnect the equipment from the mains and thus is not to be used as a safety switch.



It is the responsibility of the user or the person installing the MCD3000 to provide proper grounding and branch circuit protection according to the National Electric Code (NEC<sup>®</sup>) and local codes.

**■ Warning against unintended start**

1. The motor can be brought to a stop by means of digital commands, bus commands or a local stop, while the soft starter is connected to the mains. If personal safety considerations make it necessary to ensure that no unintended start occurs, these stop functions are not sufficient.
2. A motor that has been stopped may start if faults occur in the electronics of the soft starter, or if the soft starter's Auto Reset function has been activated and a temporary fault in the supply mains or the motor connection ceases.

**■ Symbols used in this manual**

When reading this manual you will come across different symbols that require special attention. The symbols used are the following:



Indicates something to be noted by the reader



Indicates a general warning



Indicates a high voltage warning

**■ Avoiding soft starter damage**

Please read and follow all instructions in this manual. Additionally, take special note of the following:

1. Do not connect power factor correction capacitors to the soft starter output. Static power factor correction, if used, must be connected on the mains side of the soft starter.
2. Do not apply voltage to the MCD3000 control inputs. The inputs are active 24 VDC and must be controlled with potential free circuits.
3. When installed in non-ventilated enclosures, soft starters should be used with a bypass contactor to prevent excessive enclosure temperatures.
4. When bypassing a soft starter take care to ensure phase connections are correct. i.e. B1-T1, L2-T2, B3-T3.
5. When using the DC Brake function ensure the DC Braking contactor is connected across output terminals T2-T3 only and that it operates only when the braking function is operating. Incorrect connection or operation will cause soft starter damage.



Electrostatic Precaution; Electrostatic discharge (ESD). Many electronic components are sensitive to static electricity. Voltages so low that they cannot be felt, seen or heard, can reduce the life, affect performance, or completely destroy sensitive electronic components. When performing service, proper ESD equipment should be used to prevent possible damage from occurring.

**Spare Parts**
**■ Spare Parts**

Main Control Module	Part Number	MCD3007	MCD3015	MCD3018	MCD3022	MCD3030	MCD3037	MCD3045	MCD3055	MCD3075	MCD3090	MCD3110	MCD3132	MCD3185	MCD3220	MCD3300	MCD3315	MCD3400	MCD3500	MCD3600	MCD3700	MCD3800
		(number per unit)																				
175G5088 (0DCC1 / 991-00448-00)		1	1	1	1	1	1	1	1													
175G5089 (0DCC2 / 991-00453-00)										1	1	1	1	1	1	1	1	1	1	1	1	1

175G5088 (0DCC1 / 991-00448-00)

175G5089 (0DCC2 / 991-00453-00)

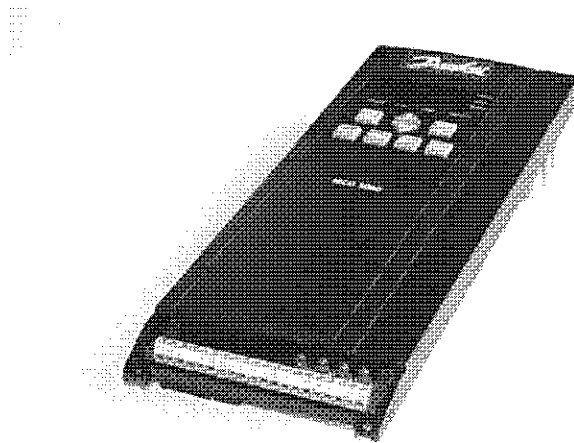
**Identifying Main Control Modules**

The two Main Control Module types can be identified by the PCB number. This number is etched on the actual printed circuit board.

Turn the Main Control Module over so you are looking at the printed circuit board. The number is etched on the board in the upper left region. (The characters either side are not relevant).

Part Number	PCB No.
175G5088	x1325x
175G5089	x1326x

Identity Module Line Connection  Part Number	MCD3007	MCD3015	MCD3018	MCD3022	MCD3030	MCD3037	MCD3045	MCD3055	MCD3075	MCD3090	MCD3110	MCD3132	MCD3185	MCD3220	MCD3300	MCD3315	MCD3400	MCD3500	MCD3600	MCD3700	MCD3800
	(number per unit)																				
175G5090 (0DCT007 / 990-00673-00)	1																				
175G5091 (0DCT015 / 990-00446-00)		1																			
175G5092 (0DCT018 / 990-00447-00)			1																		
175G5093 (0DCT022 / 990-00677-00)				1																	
175G5094 (0DCT030 / 990-00449-00)					1																
175G5095 (0DCT037 / 990-00682-00)						1															
175G5096 (0DCT045 / 990-00455-00)							1														
175G5097 (0DCT055 / 990-00456-00)								1													
175G5098 (0DCT075 / 990-00697-00)									1												
175G5099 (0DCT090 / 990-00698-00)										1											
175G5100 (0DCT110 / 990-00699-00)											1										
175G5101 (0DCT132 / 990-00700-00)												1									
175G5102 (0DCT185 / 990-00741-00)													1								
175G5103 (0DCT220 / 990-00742-00)														1							
175G5104 (0DCT300 / 990-00743-00)															1						
175G5105 (0DCT315 / 990-00744-00)																1					
175G5106 (0DCT400 / 990-00745-00)																	1				
175G5107 (0DCT500 / 990-00746-00)																		1			
175G5108 (0DCT600 / 990-00892-00)																			1		
175G5109 (0DCT700 / 990-00893-00)																				1	
175G5110 (0DCT800 / 990-00894-00)																					1

All Types

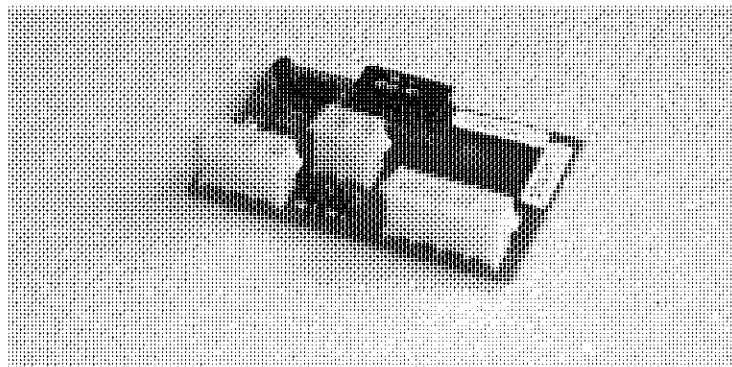

Spare Parts

Identity Module  
Inside Delta Connection

Part Number	MCD3007	MCD3015	MCD3018	MCD3022	MCD3030	MCD3037	MCD3045	MCD3055	MCD3075	MCD3090	MCD3110	MCD3132	MCD3185	MCD3220	MCD3300	MCD3315	MCD3400	MCD3500	MCD3600	MCD3700	MCD3800
	(number per unit)																				
175G3052 (990-02002-00)													1								
175G3053 (990-02003-00)														1							
175G3054 (990-02004-00)															1						
175G3055 (990-02005-00)																1					
175G3056 (990-02006-00)																	1				
175G3057 (990-02007-00)																		1			
175G3058 (990-02008-00)																			1		
175G3059 (990-02009-00)																				1	
175G3060 (990-02010-00)																					1

All Types

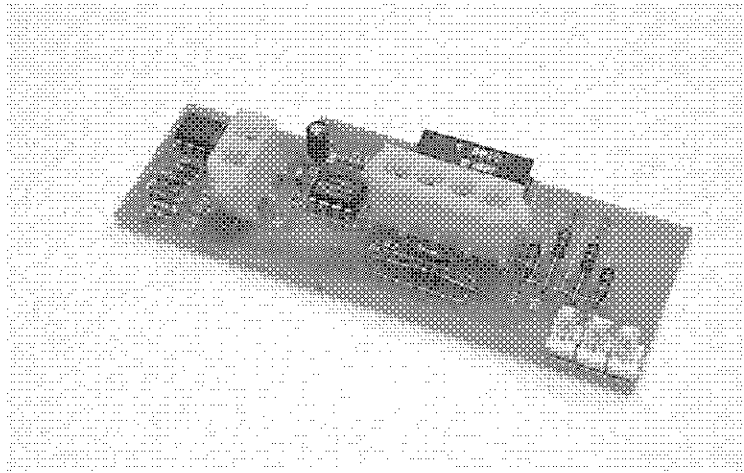



Snubber/Overtoltage Protection Module		Part Number																					
		MCD3007	MCD3015	MCD3018	MCD3022	MCD3030	MCD3037	MCD3045	MCD3055	MCD3075	MCD3090	MCD3110	MCD3132	MCD3185	MCD3220	MCD3300	MCD3315	MCD3400	MCD3500	MCD3600	MCD3700	MCD3800	
T5 (200~525V)	T7 (200~690V)	(number per unit)																					
(Not required)	175G5115 (ODSB1H / 990-00451-00)	1	1	1	1	1	1	1															
175G5112 (ODSB2 / 990-00695-00)	175G5116 (ODSB2H / 990-00696-00)									1	1	1	1										
175G5113 (ODSB4 / 990-00739-00)	175G5117 (ODSB4H / 990-00740-00)													2	2	2	2	2	2				
175G5114 (ODSB5 / 990-00895-00)	175G5118 (ODSB5H / 990-00896-00)																			6	6	6	

175G5115 (ODSB1H / 990-00451-00)

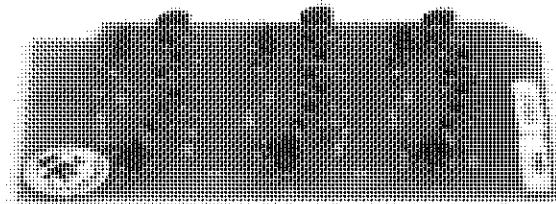

175G5112 (ODSB2 / 990-00695-00)  
175G5116 (ODSB2H / 990-00696-00)

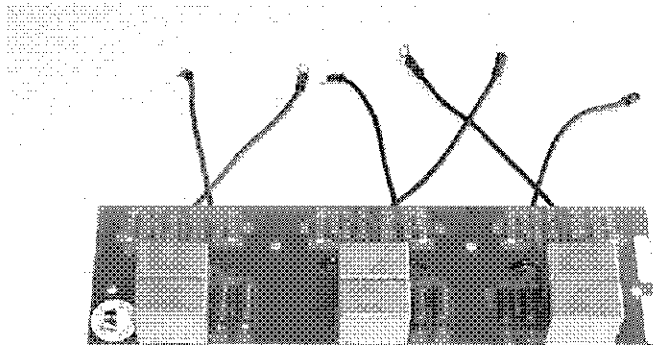

175G5113 (ODSB4 / 990-00739-00)  
175G5117 (ODSB4H / 990-00740-00)

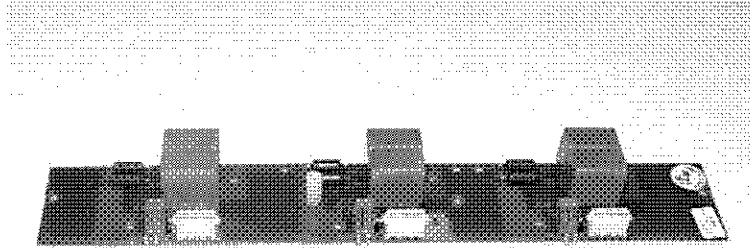

175G5114 (ODSB5 / 990-00895-00)  
175G5118 (ODSB5H / 990-00896-00)

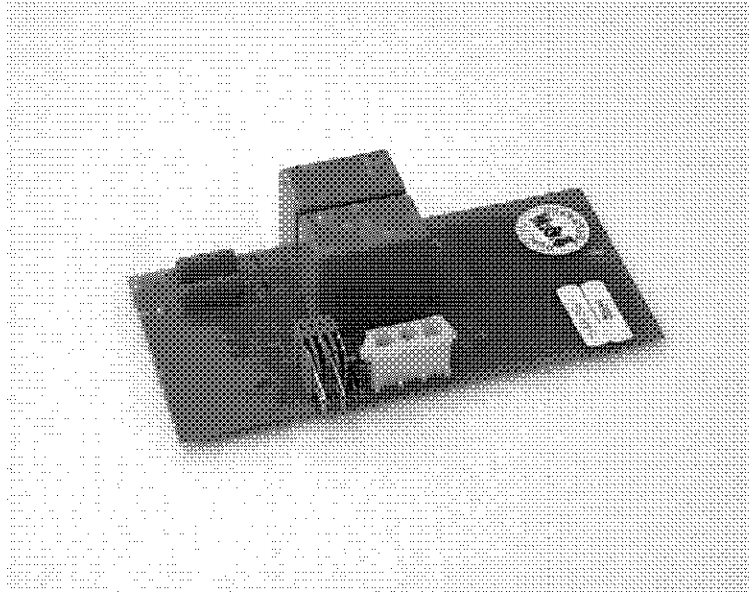

SCRs / Power Assemblies

Part Number	MCD3007	MCD3015	MCD3018	MCD3022	MCD3030	MCD3037	MCD3045	MCD3055	MCD3075	MCD3090	MCD3110	MCD3132	MCD3185	MCD3220	MCD3300	MCD3315	MCD3400	MCD3500	MCD3600	MCD3700	MCD3800
	(number per unit)																				
<b>SCRs</b>																					
175G5119 (SKKT27/16)	3																				
175G5120 (SKKT57/16)		3																			
175G5121 (SKKT72/16)			3																		
175G5122 (SKKT92/16)				3	3																
175G5123 (SKKT122/16)						3															
175G5124 (SKKT132/16)							3														
175G5125 (TT162N16)								3	3												
175G5126 (TT250N16)										3											
175G5127 (TT330N16)											3	3									
<b>Power Assemblies</b>																					
(number per unit)																					
175G5128 (8DAT185 / 994-00715-00)														2							
175G5129 (8DAT220 / 994-00717-00)															2						
175G5130 (8DAT300 / 994-00719-00)																2					
175G5131 (8DAT315 / 994-00721-00)																	2				
175G5132 (8DAT400 / 994-00723-00)																		2			
175G5133 (8DAT500 / 994-00725-00)																			2		
175G5134 (8DAT600 / 994-00207-00)																				2	
175G5135 (8DAT700 / 994-00986-00)																					2
175G5136 (8DAT800 / 994-00988-00)																					2

- 175G5119 (SKKT27/16)
- 175G5120 (SKKT57/16)
- 175G5121 (SKKT72/16)
- 175G5122 (SKKT92/16)

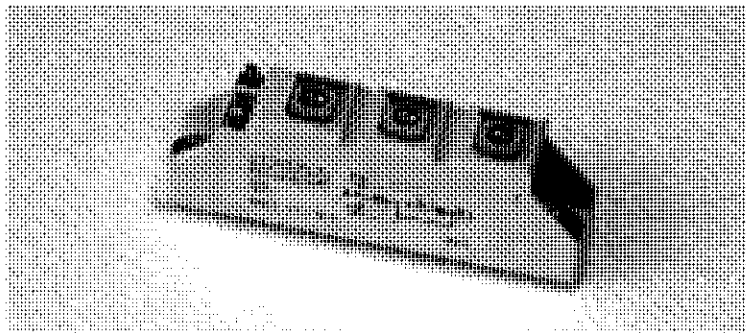

175G5123 (SKKT122/16)  
175G5124 (SKKT132/16)  
175G5125 (TT162N16)

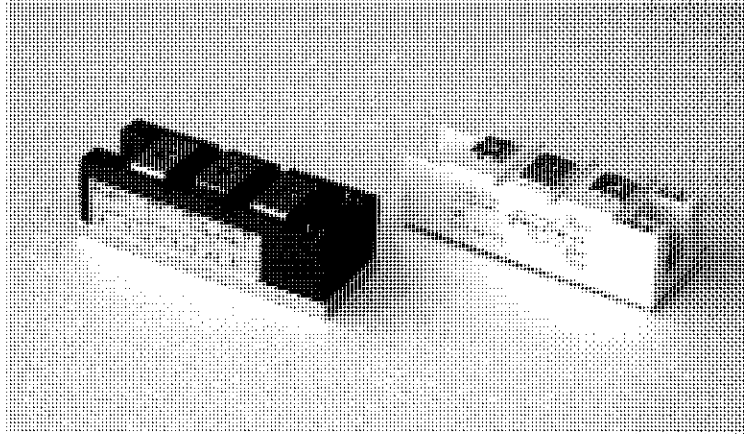

175G5126 (TT250N16)  
175G5127 (TT330N16)

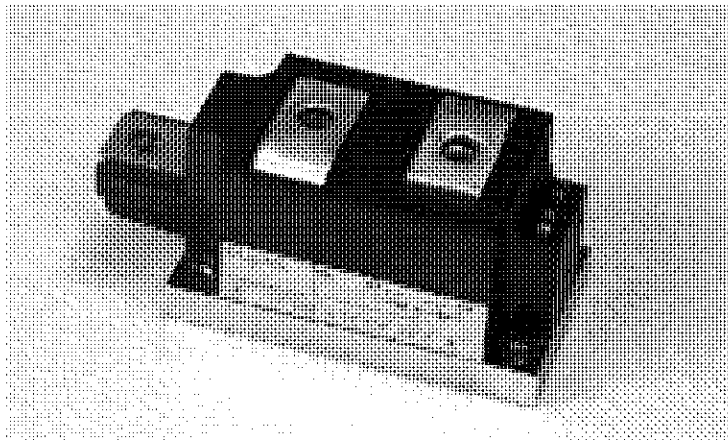

- 175G5128 (8DAT185 / 994-00715-00)
- 175G5129 (8DAT220 / 994-00717-00)
- 175G5130 (8DAT300 / 994-00719-00)
- 175G5131 (8DAT315 / 994-00721-00)
- 175G5132 (8DAT400 / 994-00723-00)
- 175G5133 (8DAT500 / 994-00725-00)

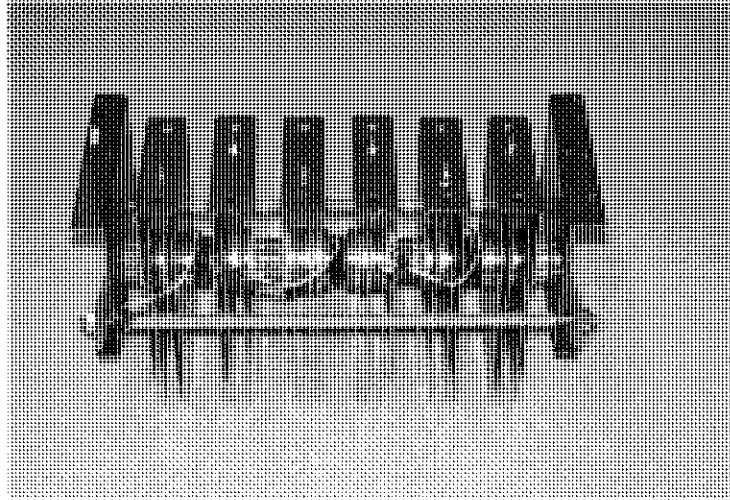

- 175G5134 (8DAT600 / 994-00207-00)
- 175G5135 (8DAT700 / 994-00986-00)
- 175G5136 (8DAT800 / 994-00988-00)

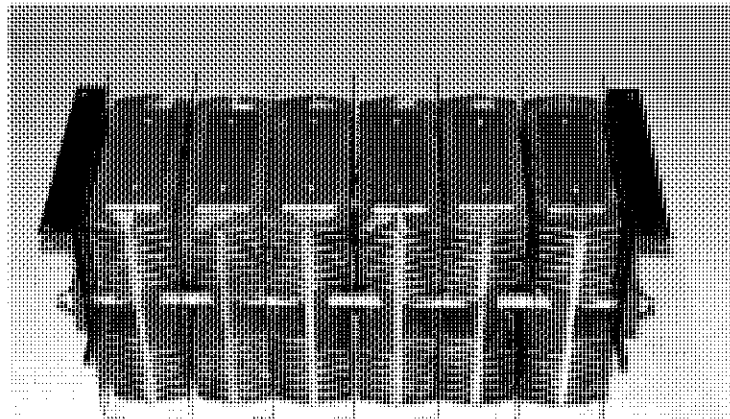

Spare Parts

Cooling Fans

Part Number	MCD3007	MCD3015	MCD3018	MCD3022	MCD3030	MCD3037	MCD3045	MCD3055	MCD3075	MCD3090	MCD3110	MCD3132	MCD3185	MCD3220	MCD3300	MCD3315	MCD3400	MCD3500	MCD3600	MCD3700	MCD3800
	(number per unit)																				
175G5137 (4214HR)					1	1	1	1	2	2	2	3									
175G5138 (7214NR)													2	2	2	2	2	2	3	3	3

175G5137 (4214HR)

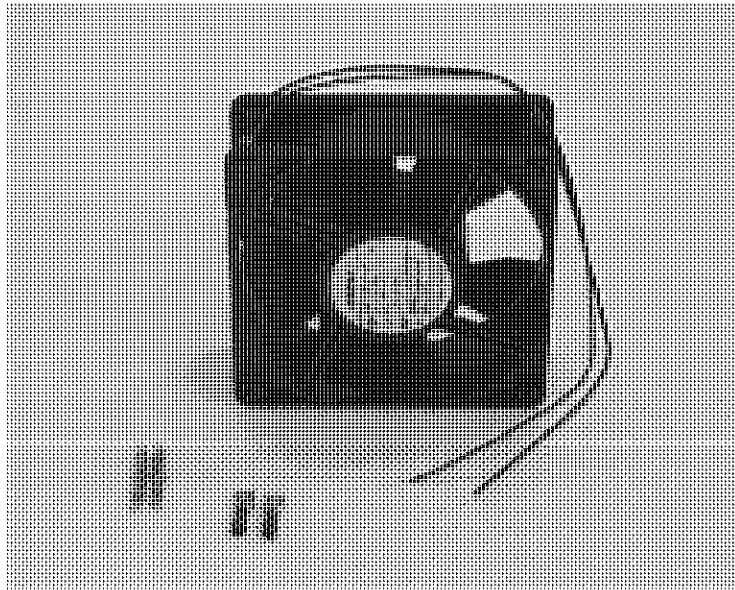

175G5138 (7214NR)

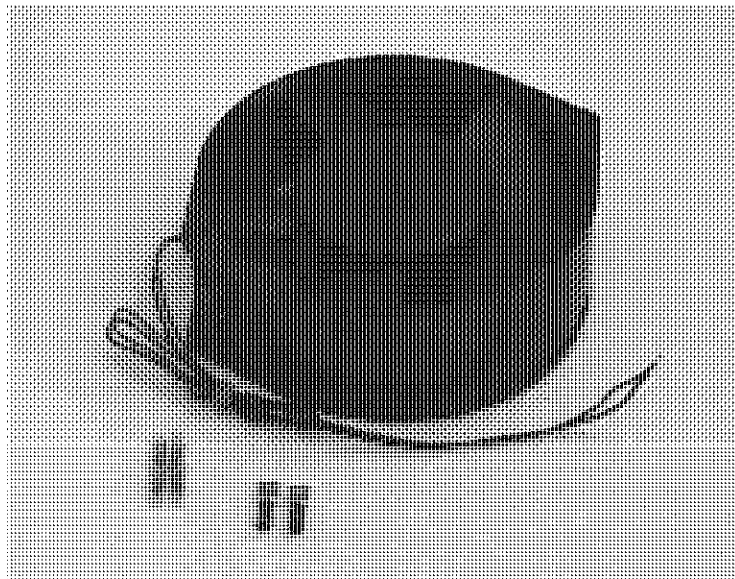

Power Transformers

Part Number		MCD3007	MCD3015	MCD3018	MCD3022	MCD3030	MCD3037	MCD3045	MCD3055	MCD3075	MCD3090	MCD3110	MCD3132	MCD3185	MCD3220	MCD3300	MCD3315	MCD3400	MCD3500	MCD3600	MCD3700	MCD3800	
CV4 (230V/400V)	CV2 (110V/230V)	(number per unit)																					
175G5139 (1PT10AV)	175G5150 (1PT10DV)	1	1	1	1																		
175G5140 (1PT17AT)	175G5151 (1PT17DT)					1	1	1	1														
175G5141 (1PT23AT)	175G5152 (1PT23DT)									1	1	1											
175G5142 (1PT40AT)	175G5153 (1PT40DT)												1	1	1	1	1	1	1				
175G5143 (1PT55AT)	175G5154 (1PT55DT)																			1	1	1	

175G5139 (1PT10AV)  
175G5150 (1PT10DV)

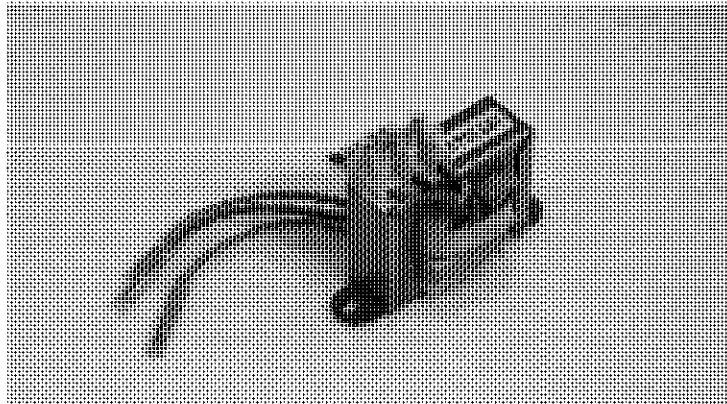

175G5140 (1PT17AT)  
175G5151 (1PT17DT)

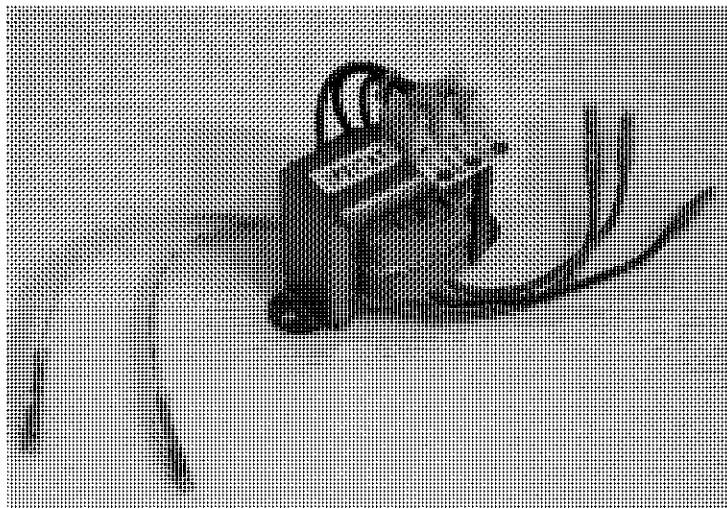

175G5141 (1PT23AT)  
175G5152 (1PT23DT)

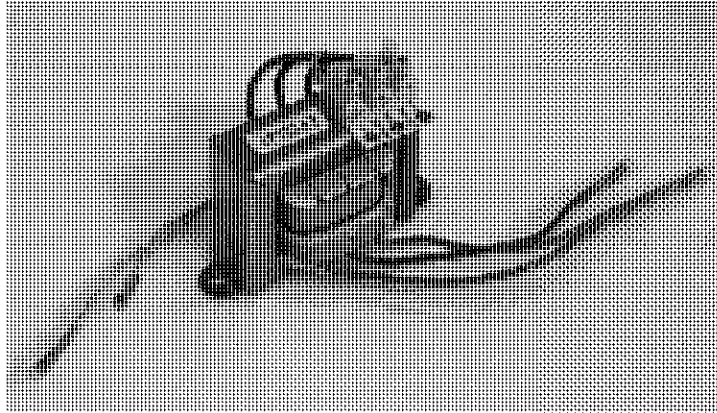

175G5142 (1PT40AT)  
175G5153 (1PT40DT)

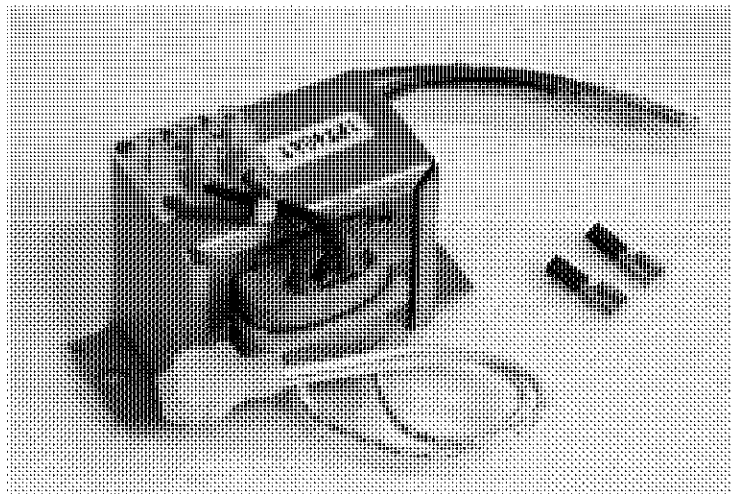

175G5143 (1PT55AT)  
175G5154 (1PT55DT)

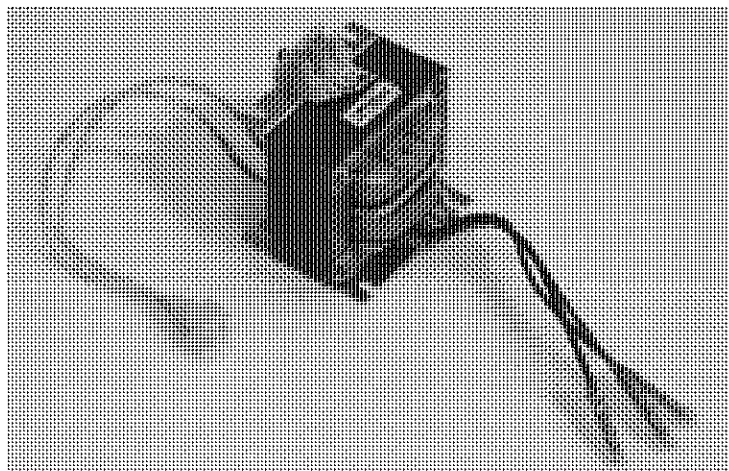



**■ Tests**

The MCD3000 soft starter operation can be verified using various dynamic test procedures. There is also a static test procedure that will give accurate information on the condition of the soft starter. The following information details the test procedures, test equipment required and actions to be taken from the test results.

**Start Performance Test**

This is a dynamic test that verifies the correct operation of the MCD3000 soft starter during “start mode”. You will need a suitably rated ammeter. Best results are achieved using a clip on analogue ammeter. Use the following procedure:

1. Determine the expected start current by multiplying the programmed Motor Full Load Current (Parameter 1) by the Current Limit (Parameter 2).
2. Start the motor and measure the actual start current.
3. If the expected start current and the measured start current are the same, the soft starter is performing correctly.
4. If there is a large variation between the expected start current and the measured start current, this could indicate a faulty MCD3000 Main Control Module or internal Current Transformer. Exchange the Main Control Module. If the fault remains check the Current Transformers by measuring the secondary resistance for continuity and visually inspecting these circuits.
5. If Current Ramp start mode is used, the minimum expected start current is the programmed Motor Full Load Current (Parameter 1) multiplied by the Initial Current (Parameter 3). Continue with Steps 2 to 4 detailed above.

**Run Performance Test**

This is a dynamic test that verifies the correct operation of the MCD3000 soft starter during “run mode”. You will need a suitably rated voltmeter. Use the following procedure:

1. Ensure that the soft starter is in “run mode”. This can be verified by making sure the “Run” LED located on the soft starter front display panel is illuminated.
2. Measure the voltage across each phase of the soft starter, ie.L1/T1, L2/T2, L3/T3.
3. The measured voltage should be less than 2VAC when the soft starter is operating correctly. If the voltage is significantly greater than 2VAC this could indicate:
  - A faulty firing circuit on the Main Control Module. Exchange the Main Control Module to see if the fault is removed.

- A faulty SCR gate circuit. With a multimeter, measure the gate resistance (anode to cathode / cathode to anode) of the suspect SCR. Comparative readings should be taken with a known healthy SCR device. If the test results are erroneous, replace the SCR.
- A faulty firing loom circuit. Perform a continuity test on the firing loom circuit and visually inspect for a loose connection.

**Power Circuit Test**

This is a static test that verifies the condition of the MCD3000 soft starter SCRs, firing looms and Main Control Module. You will need a 500VDC insulation tester. A recommended model is the “Megger BM101/3” or similar. Do not use a hand generated insulation tester or a standard multimeter (analogue or digital). These will give erroneous test results. Use the following procedure:

1. Completely isolate the soft starter so that there are no main power connections to busbars L1, L2, L3 and T1, T2, T3. For safety, remove the control supply power to the soft starter terminals A1/A2 or A2/A3.
2. Using a suitable insulation tester measure the resistance across each phase of the soft starter, ie.L1/T1, L2/T2, L3/T3. These measurements should also be taken in the reverse direction, ie. T1/L1, T2/L2, T3/L3.
3. A resistance measurement of 33 to 40kΩ across each phase indicates a healthy condition. All readings should be similar.
4. A resistance of less than 10kΩ would indicate that the SCR power device is suffering from excessive leakage or a complete short circuit. Replace the faulty SCR and analyse the system for common causes of SCR failure (Refer to Section 5.1, Typical Causes of SCR Damage).

**NB!**

Damage to an SCR does not necessitate mandatory replacement of the MCD3000 Main Control module. Replace of the Main Control module should be considered only after first having replaced the damaged SCR(s) and tested the MCD3000 for correct operation.

5. A resistance of greater than 60kΩ could indicate a faulty Main Control Module or firing loom. Exchange the Main Control Module to see if the fault is removed. If the fault remains, check the firing loom for continuity and inspect all connections.

**Tests**
**Control Input Test**

This is a dynamic test that verifies the correct operation of the MCD3000 soft starter remote control inputs. This test must be performed with the soft starter powered up. You will need a low voltage DC multimeter. Use the following procedure:

1. With nothing connected into a remote control input, the input status LED (yellow) should be extinguished.
2. Measure the voltage across the remote control input. It should be between 18 and 24VDC.
3. If the measured voltage is significantly less than 18VDC this could indicate damage to the remote control input circuit of the MCD3000 Main Control Module. Exchange the Main Control Module to see if the fault is removed. This damage is caused by external voltage applied to the remote control input. These inputs are active 24VDC and must be controlled with volt free contacts. (Refer to Section 5.3, Remote Control Input failure).
4. With an externally closed contact/switch connected into a remote control input, the input status LED (yellow) should be illuminated.
5. The measured voltage across the remote control input should be close to zero VDC.
6. If the measured voltage is significantly higher than 18VDC this could indicate a faulty external field contact/switch or a break in the external control circuitry. This fault can be verified by removing the external control circuit wired into the remote control input and replacing this with a wire link at the soft starter remote control input terminal. The measured voltage across this input should be close to zero VDC.

**Power Transformer Test**

This is a dynamic test that verifies the MCD3000 soft starter control supply transformer (PT). This test must be performed with the soft starter control supply power on. You will need a low voltage AC multimeter. Use the following procedure:

1. The control supply transformer has a secondary winding consisting of two orange wires and one purple wire. These three wires along with an earth wire are connected to a plastic connector block that the Main Control Module is seated into.
2. Remove the Main Control Module from the soft starter.
3. At the plastic connector block measure the voltage between each orange wire and the purple wire. This should be 9 to 14VAC. If no voltage is present the control transformer could be faulty or no control supply is present at terminals A1/A2 or

- A2/A3 of the MCD3000 soft starter. If the measured voltage is less than 40% of the expected voltage, check the external power supply. The supply connected to terminals A1/A2 or A2/A3 of the soft starter could be incorrect.
4. At the plastic connector block measure the voltage between the two orange wires. This should be 18 to 28VAC. If no voltage is present the control transformer could be faulty or no control supply is present at terminals A1/A2 or A2/A3 of the MCD3000 soft starter. If the measured voltage is less than 40% of the expected voltage, check the external power supply. The supply connected to terminals A1/A2 or A2/A3 of the soft starter could be incorrect.
5. On models MCD3030 to MCD3800 the control supply transformer has a secondary winding consisting of two white wires. On models MCD3030 to MCD3110, these wires are connected to the Identity Module. On models MCD3132 to MCD3800, these wires are connected to a bridge rectifier.
6. Measure the voltage between the two white wires at the Identity Module or the bridge rectifier. This should be 18 to 28VAC. If no voltage is present the control transformer could be faulty or no control supply is present at terminals A1/A2 or A2/A3 of the soft starter. If the measured voltage is less than 40% of the expected voltage, check the external power supply. The supply connected to terminals A1/A2 or A2/A3 of the soft starter could be incorrect.



**ALWAYS VERIFY A SUSPECT MAIN CONTROL MODULE BY REFITTING IT BACK ONTO THE SOFT STARTER UNIT TO SEE IF THE FAULT REMAINS.**



The MCD3000 contains dangerous voltages when connected to line voltage.

Only a competent electrician should carry out the electrical testing procedures. Improper testing of the MCD3000 may cause equipment failure, serious injury or death. Follow these procedures, National Electrical Codes (NEC®) and local safety codes.

■ Component Replacement Procedures

**Control Module: MCD3007 ~ MCD3132**

**Step 1.** Undo fixing screws (2) and remove lower terminal cover.

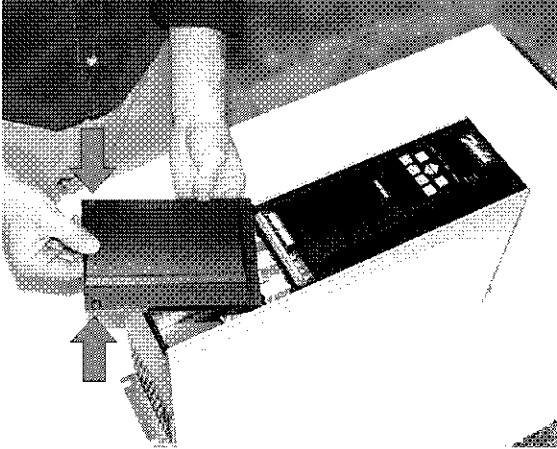

**Step 2.** Undo fixing screws (4) and lift off Control Module.

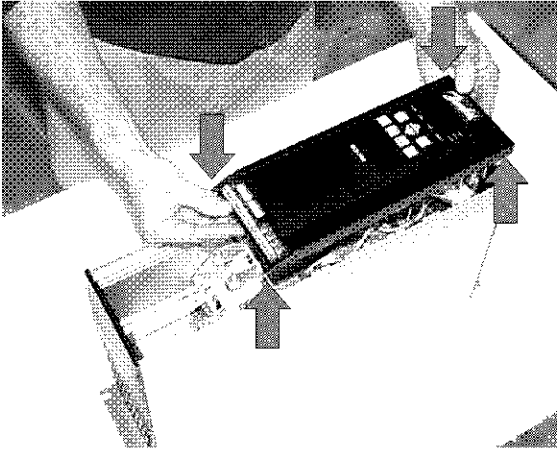

**NB!**  
Lift the control module straight off.  
DO NOT Pivot.

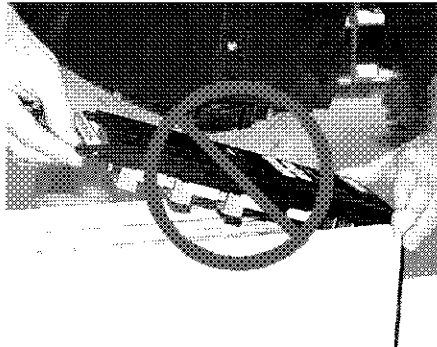

**Step 3.** Fit new Control Module in reverse order.

**Control Module: MCD3185 ~ MCD3800**

**Step 1.** Undo fixing screws (4) and remove front cover.

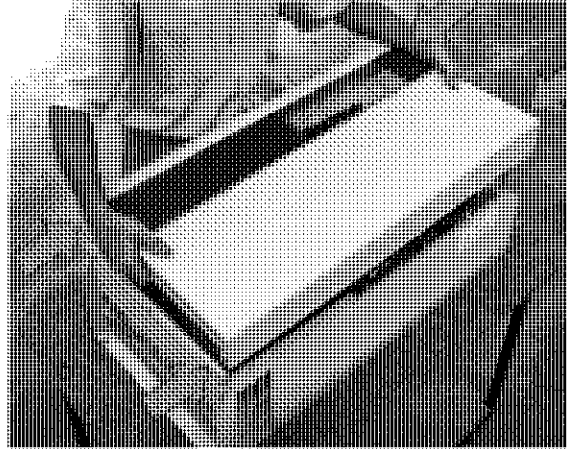

**Step 2.** Undo fixing screws (4) and lift off Control Module.

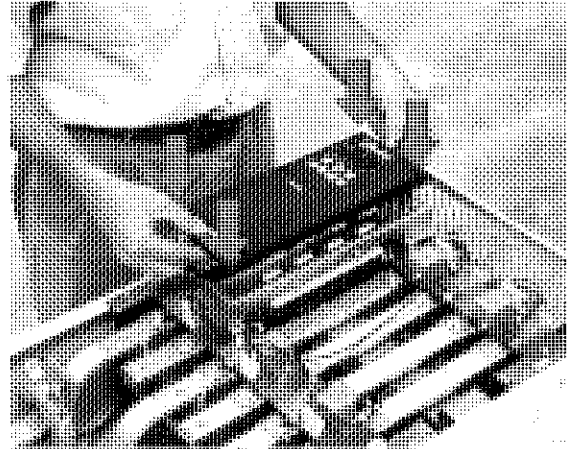

**NB!**  
Lift the control module straight off.  
DO NOT Pivot.

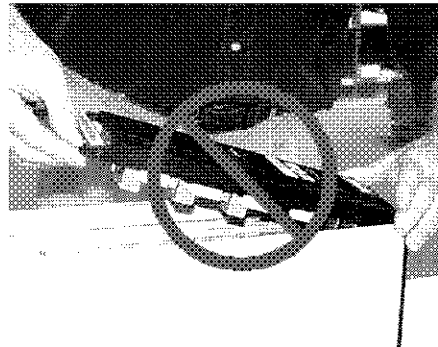

**Step 3.** Fit new Control Module in reverse order.

**Identity Module: MCD3007 ~ MCD3132**

**Step 1.** Remove the Main Control Module using the method described on page 17. For models MCD3075~3132 also remove the aluminium face plates.

**Step 2.** Undo the screws (2) securing the top gland plate.

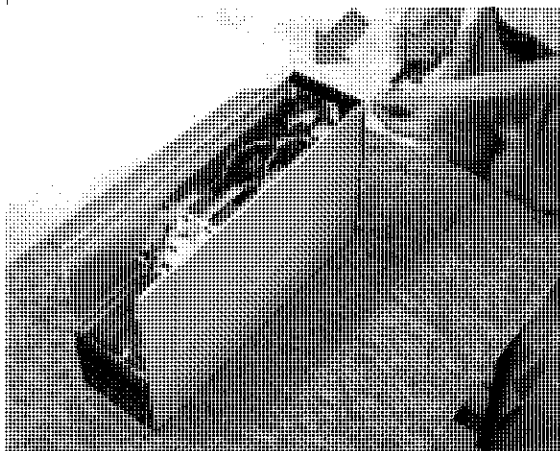

**Step 3.** Unplug all connectors attached to the Identity Module. (MCD3007~3022 = 2 connectors, MCD3030~MCD3132 = 4 connectors).

All plugs are different and have locating mechanisms to ensure they are correctly fitted.

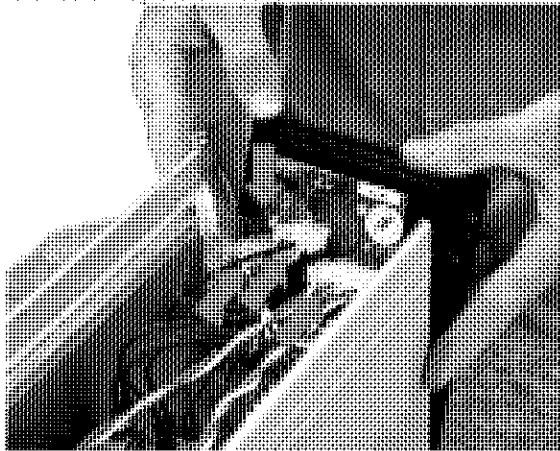

**Step 4.** Detach the Identity Module from the top gland plate (for models MCD3075~3132 the fan grill below the top gland plate must be removed to allow detachment). Fit the new Identity Module in reverse order.

**Identity Module: MCD3185 ~ MCD3800**

**Step 1.** Remove the Main Control Module using the method described on page 17.

**Step 2.** Unplug the three temperature detector plugs and the CT plug from the Identity Module.

All plugs have locating mechanisms to ensure they are correctly fitted. The three temperature detector plugs are interchangeable and can be connected to any of the temperature detector pins on the Identity Module.

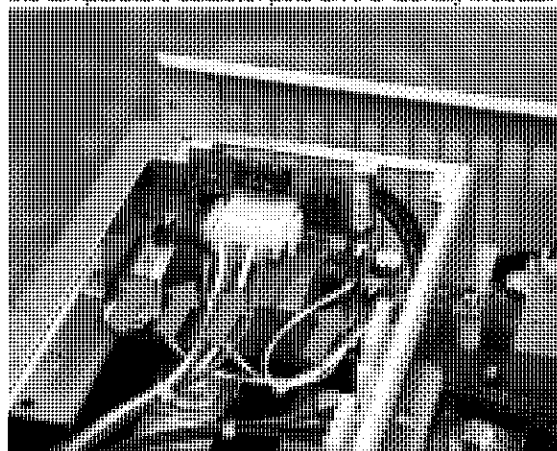

**Step 3.** Undo fixing screws (2) and remove the Identity Module.

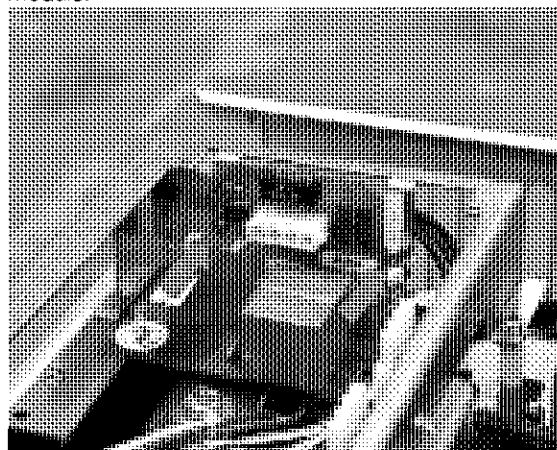

**Step 4.** Fit new Identity Module in reverse order.

**Snubber/Overvoltage Protection Module:  
MCD3007 ~ MCD3055 (T7 models only)**

**Step 1.** Disassemble the MCD3000 as described for Identity Module replacement, Steps 1 to 3 (Page 18).

**Step 2.** Carefully dislodge the firing looms (16) from the push terminals on the Snubber/Overvoltage Protection Module. Refer to the diagram below for connection detail.

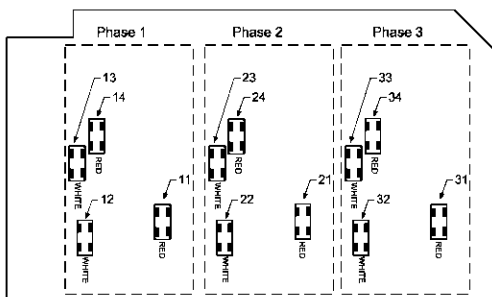
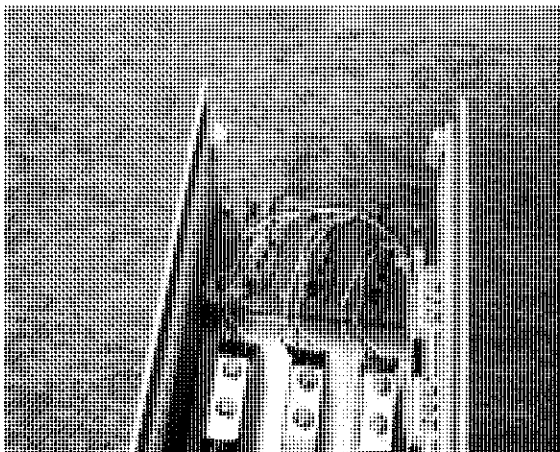

**Step 3.** Undo the fixing nuts (4) and remove the Snubber/Overvoltage Protection Module.

**Step 4.** Fit the new Snubber/Overvoltage Protection Module in reverse order.

**Snubber/Overvoltage Protection Module:  
MCD3075 ~ MCD3132**

**Step 1.** Disassemble the MCD3000 as described for Identity Module replacement, Steps 1 to 3 (Page 18).

**Step 2.** (This step required for T7 models only) Carefully dislodge the firing looms (16) from the push terminals on the Snubber/Overvoltage Protection Module. Refer to the diagram below for connection detail.

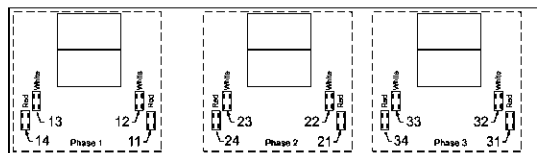
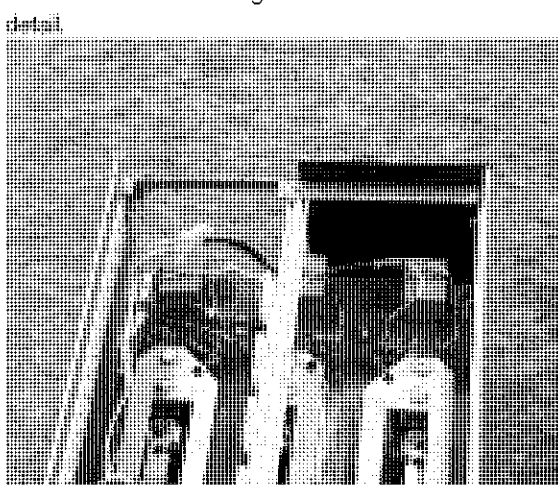

**Step 3.** Unscrew the wiring looms (6) running from the Snubber/Overvoltage Protection Module to the bus bars.



**Step 4.** Undo the fixing nuts (4) and remove the Snubber/Overvoltage Protection Module.

**Step 5.** Fit the new Snubber/Overvoltage Protection Module in reverse order.

**Snubber/Overvoltage Protection Module:  
MCD3185 ~ MCD3500**

**Step 1.** Remove the Main Control Module using the method described on page 17.

**Step 2.** Unplug the three temperature detector plugs and the CT plug from the Identity Module.

All plugs have locating mechanisms to ensure they are correctly fitted. The three temperature detector plugs are interchangeable and can be connected to any of the temperature detector pins on the Identity Module.

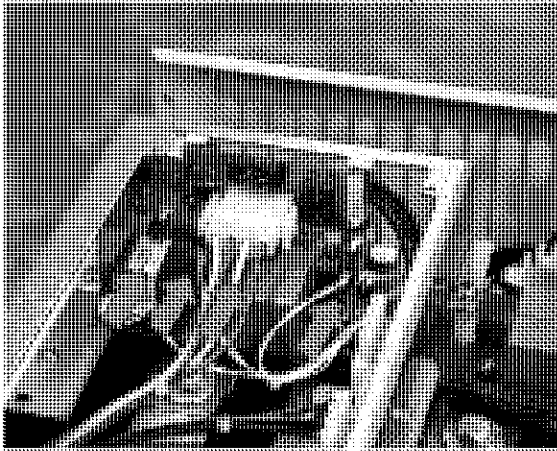

**Step 3.** Undo fixing screws (4) securing the Main Control Module Mounting bracket.

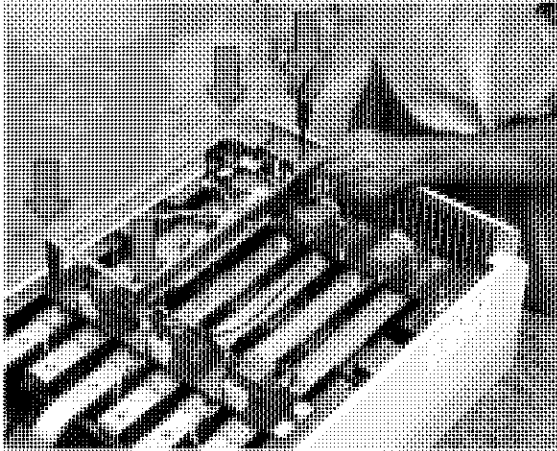

**Step 4.** Unplug the firing loom connections (3).

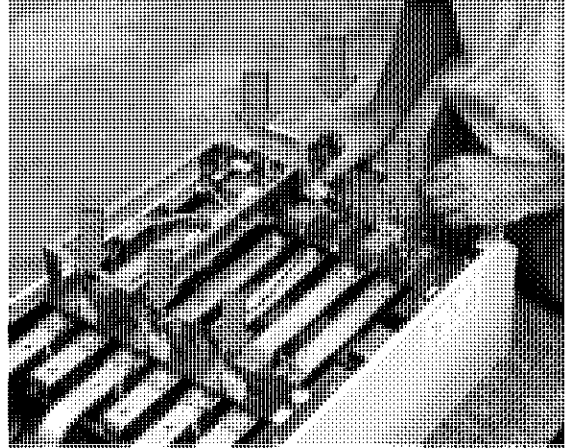

**Step 5.** Cut the cable ties that secure the firing loom to the Snubber/Overvoltage Protection Module.

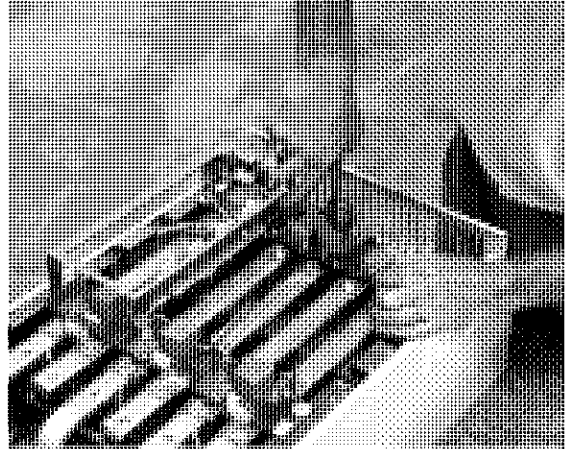

**Step 6.** Fold back the Main Control Module mounting bracket.

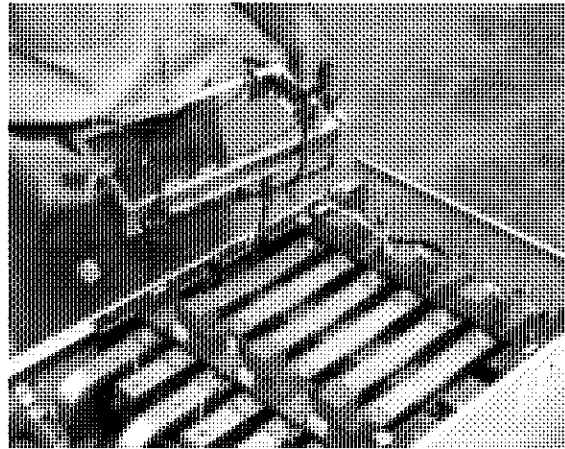

**Step 7.** Undoing the SCF leads.

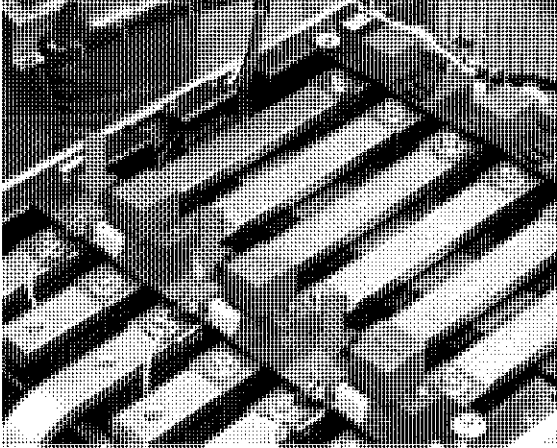

**Step 8.** Undo fixing screws (2), undo the fixing nuts (6) and remove the Snubber/Overvoltage Protection Module.

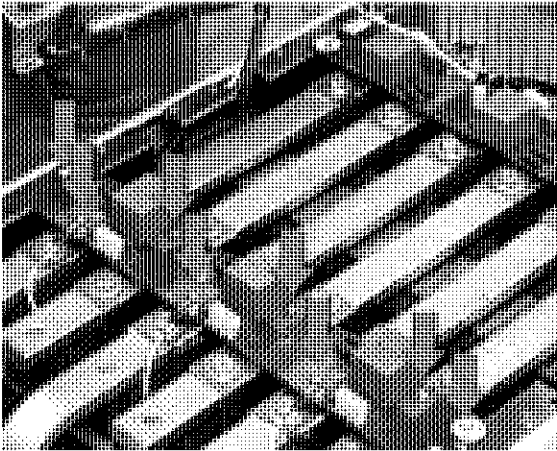

**Step 9.** Fit the new Snubber/Overvoltage Protection Module in reverse order.

**Snubber/Overvoltage Protection Module:  
MCD3600 ~ MCD3800**

**Step 1.** Undo fixing screws (4) and remove front cover.

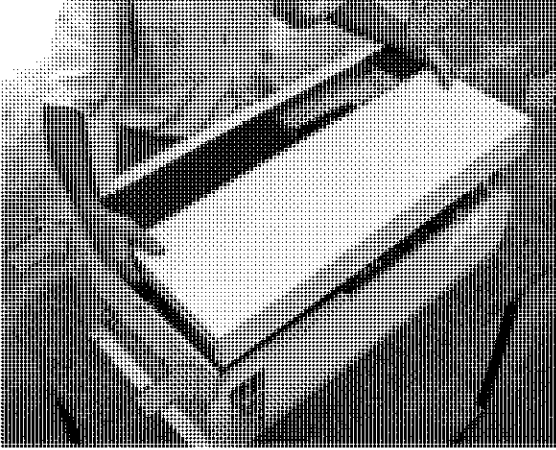

**NB!**

Steps 2~4 are required only if the Snubber/Overvoltage Module being replaced is under the control module.

**Step 2.** Undo fixing screws (4) and lift off Control Module.

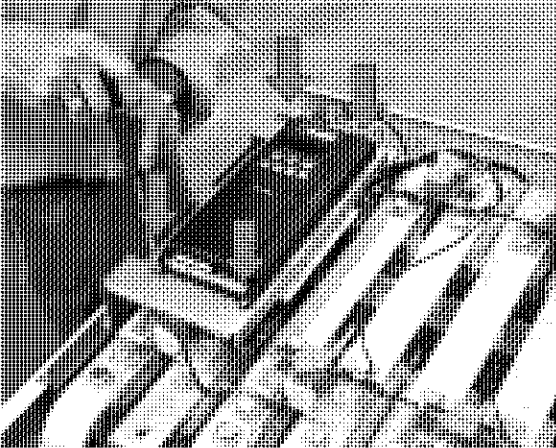

**Step 3.** Unplug the three temperature detector plugs and the CT plug from the Identity module.

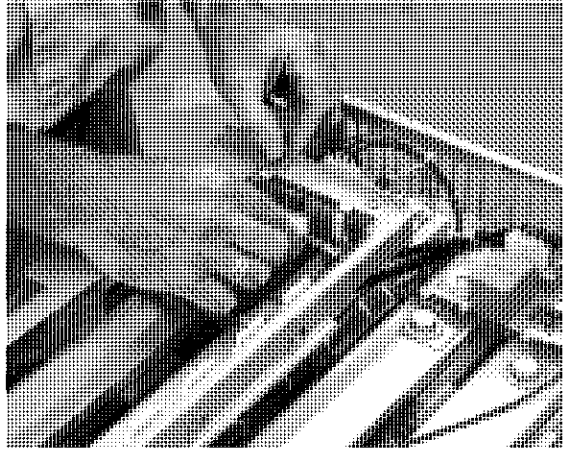

All plugs have locating mechanisms to ensure they are correctly fitted. The three temperature detector plugs are interchangeable and can be connected to any of the temperature detector pins on the Identity Module.

**Step 4.** Undo fixing screws (4) securing the Main Control Module Mounting bracket and fold back the Main Control mounting bracket.

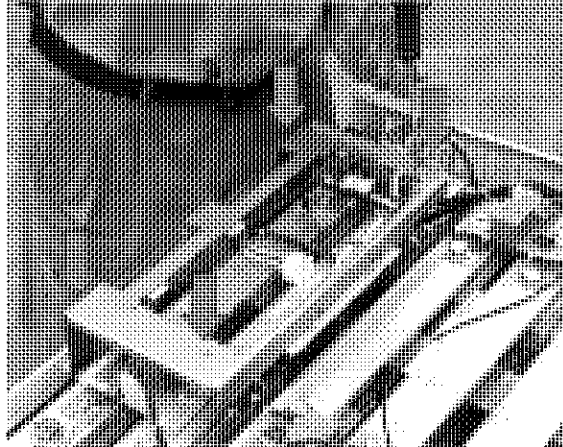

**Step 5.** Undo the firing lead connection.





**Step 6.** Undo the SCR leads.

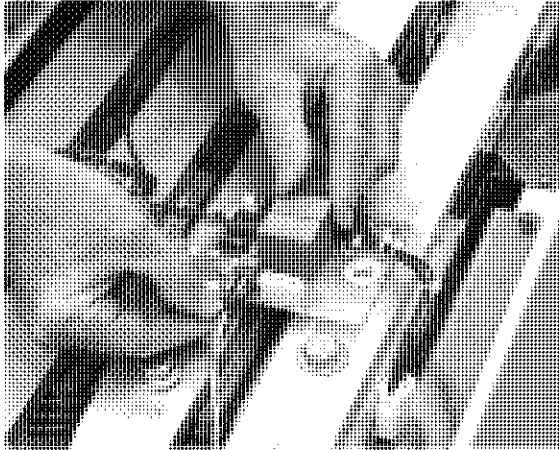

**Step 7.** Cut the cable ties that secure the firing loom to the Snubber/Overvoltage Protection Module.



**Step 8.** Undo the fixing screws (2) and remove the Snubber/Overvoltage Protection Module.

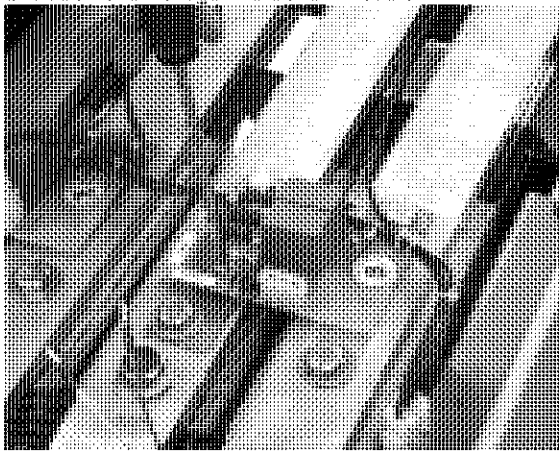

**Step 9.** Fit the new Snubber/Overvoltage Protection Module in reverse order.

### SCRs: MCD3007 ~ MCD3132

**Step 1.** Remove the Main Control Module & Identity Module using the method described on page 18.

**Step 2.** Unplug the firing looms (4) connected to the SCR being replaced.

Firing Loom Connection Detail

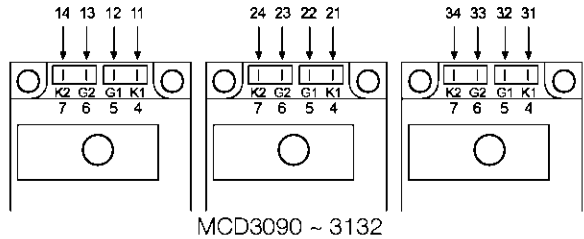
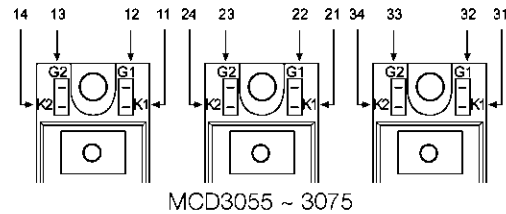
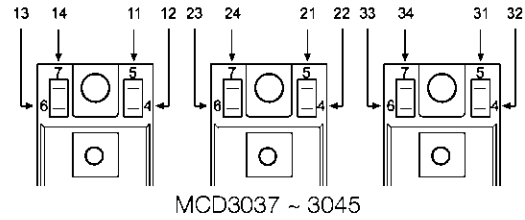
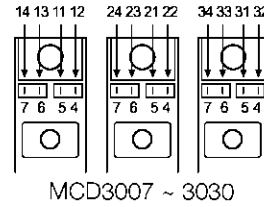

**Step 3.** Undo the screws (2) connecting the input & bypass bus bar (L1/B1, L2 or L3/B3) to the SCR being replaced.

Model	Torque
MCD3007 ~ MCD3030	4 NM
MCD3037 ~ MCD3075	7 NM
MCD3090 ~ MCD3132	12NM

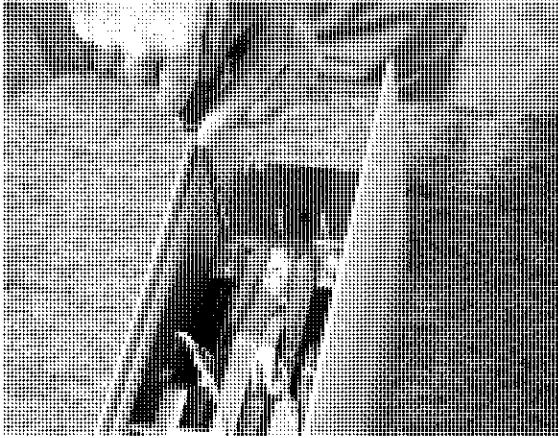

**Step 4.** Slide the bus bar (up or down depending on the model) until clear of the SCR fixing screws & the screws securing the output bus bar to the SCR.

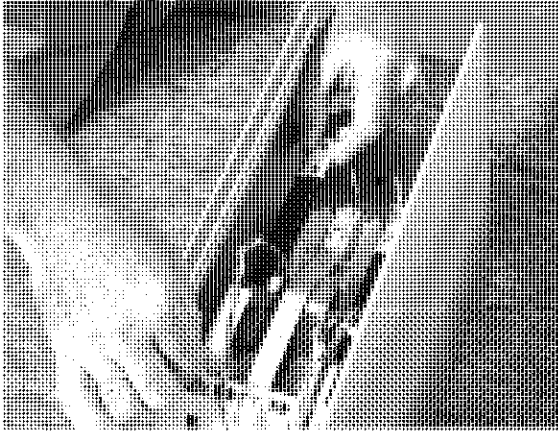

**Step 5.** Undo the screw (1) connecting the output bus bar (T1, T2 or T3) to the top of the SCR being replaced.

Model	Torque
MCD3007 ~ MCD3030	4 NM
MCD3037 ~ MCD3075	7 NM
MCD3090 ~ MCD3132	12NM

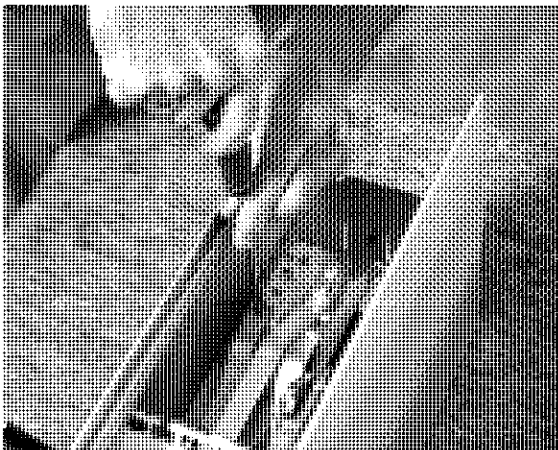

**Step 6.** Slide the bus bar (up or down depending on the model) until clear of the SCR fixing screws.

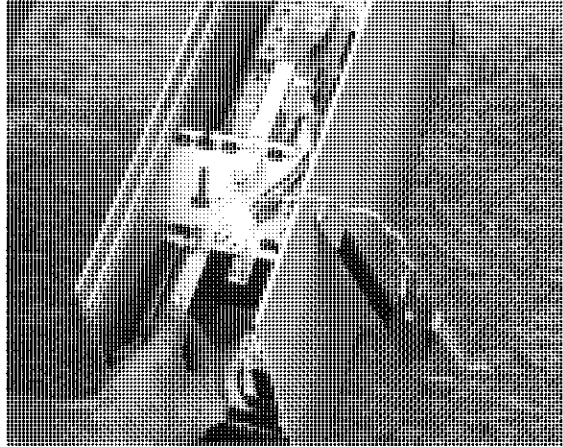

**Step 7.** Undo the screws securing the SCR to the heatsink. (Tightening Torque = 4 Nm)

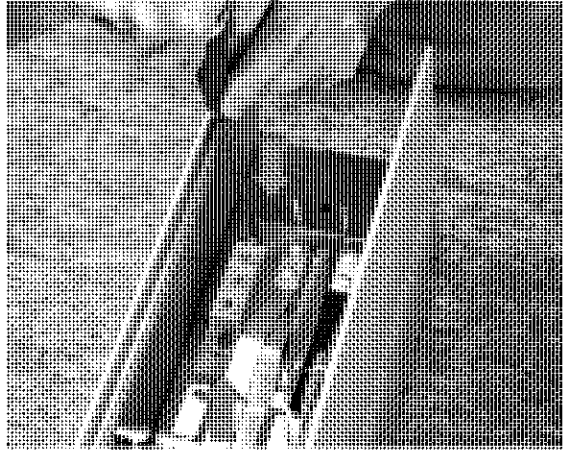

**Step 8.** Apply a thin even film of heatsink paste to the bottom of the new SCR and replace the SCR in reverse order.

**Power Assemblies: MCD3185 ~ MCD3800**

**Step 1.** Remove the Main Control Module using the method described on page 17.

**Step 2.** Unplug the three temperature detector plugs and the CT plug from the Identity Module.

All plugs have locating mechanisms to ensure they are correctly fitted. The three temperature detector plugs are interchangeable and can be connected to any of the temperature detector pins on the Identity Module.

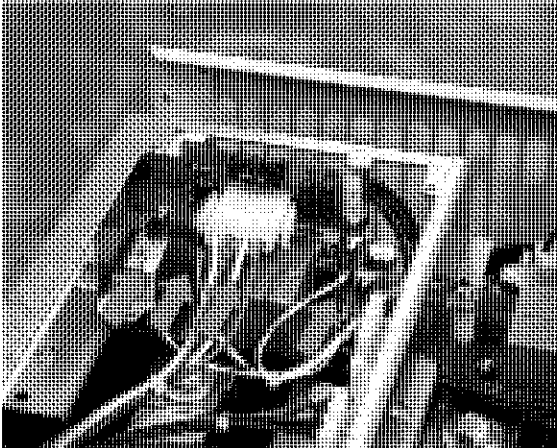

**Step 3.** Undo fixing screws (4) securing the Main Control Module Mounting bracket.

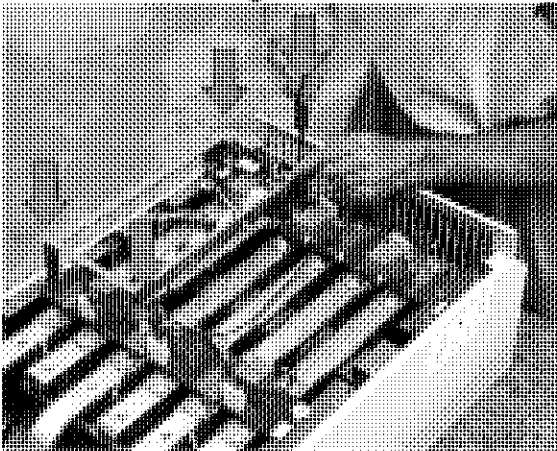

**Step 4.** Unplug the firing loom connections (C).

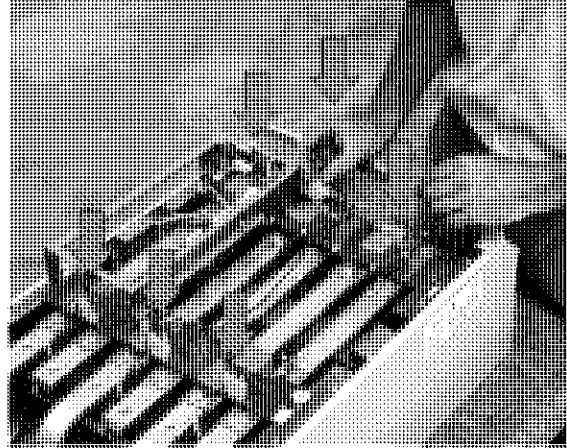

**Step 5.** Cut the cable ties that secure the firing loom to the Scrubber/Overvoltage Protection Module.

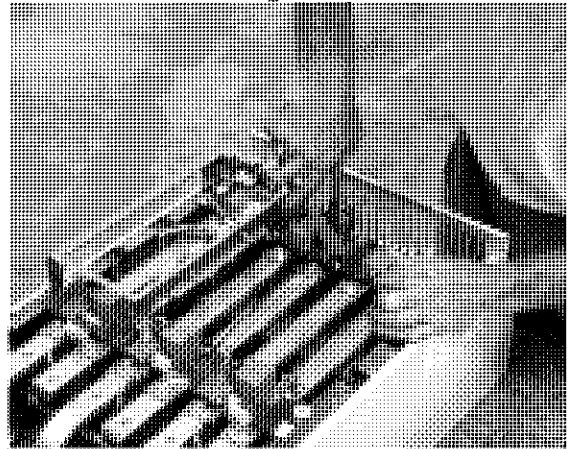

**Step 6.** Fold back the Main Control Module mounting bracket.

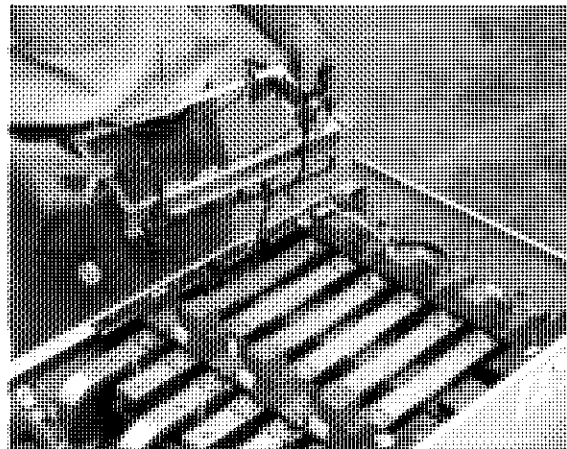

**Step 7.** Undo the CT mounting screws (4).

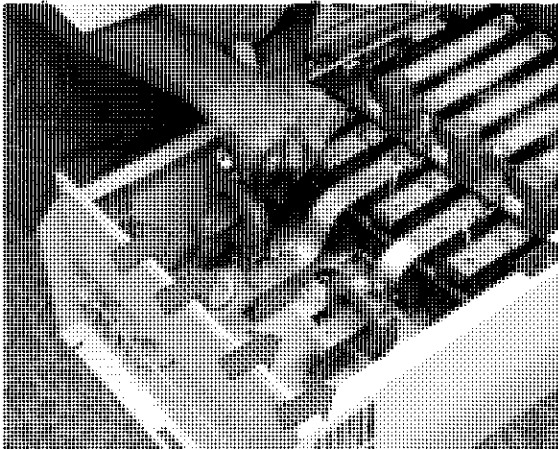

**Step 8.** Slide the CTs off the bus bars and lie on the bottom of the starter.



**Step 9.** Remove the cable entry gland plate.

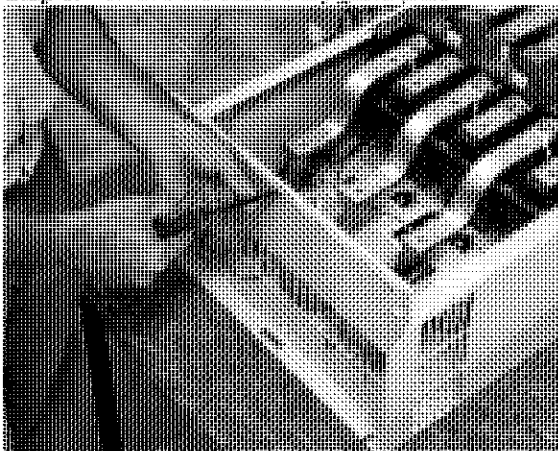

**Step 10.** Undo the bolts (24) securing the bus bars to the power assemblies. These bolts are tightened to 12NM for models MCD3185~3500, and 17NM for models MCD3600~3800.

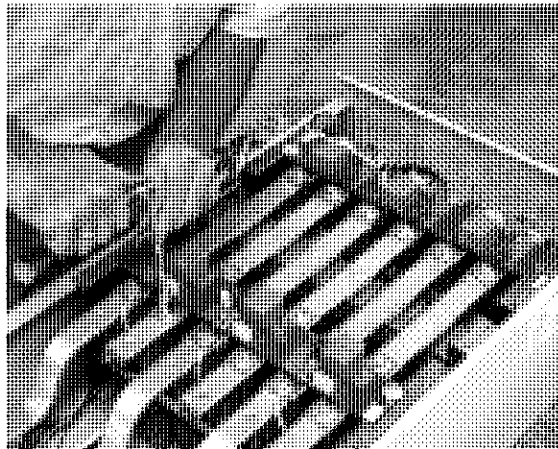

**Step 11.** Slide the bus bars out of the starter.

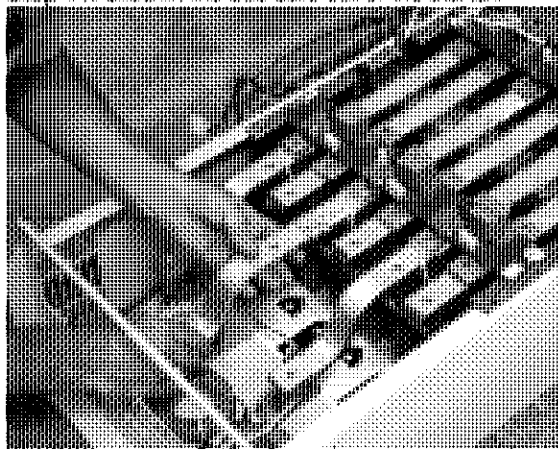

**Step 12.** Undo the Power Assembly mounting screw (4) and remove the power assembly. For models MCD3600~3800 this will also require removal of the polycarbonate fan insulation plate.

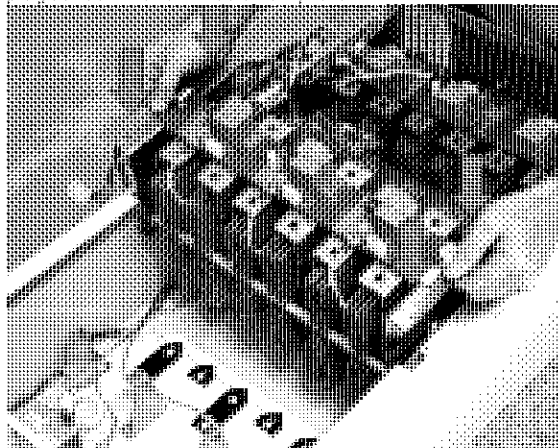

The new Power Assembly must be fitted with the same mechanical orientation as the original Power Assembly.

**Step 13.** Fit new Power Assembly in reverse order.

**Cooling Fans: MCD3030 ~ MCD3055**

**Step 1.** Disassemble the MCD3000 as described for Identity Module replacement, Steps 1 to 3 (Page 18).

**Step 2.** Remove all remaining plastic end caps and fan grills.

**Step 3.** Unplug the firing looms (4 per SCR) connected to each of the SCRs.

Firing Loom Connection Detail

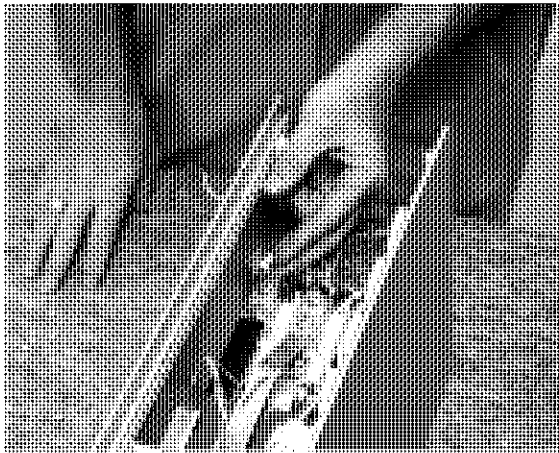
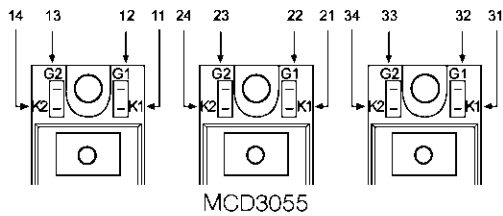
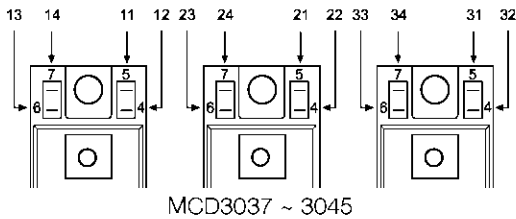
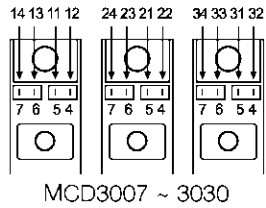

**Step 4.** Undo and remove the screws (2 per SCR) connecting the input and bypass bus bars (L1/B1, L2 & L3/B3) to each of the SCRs.

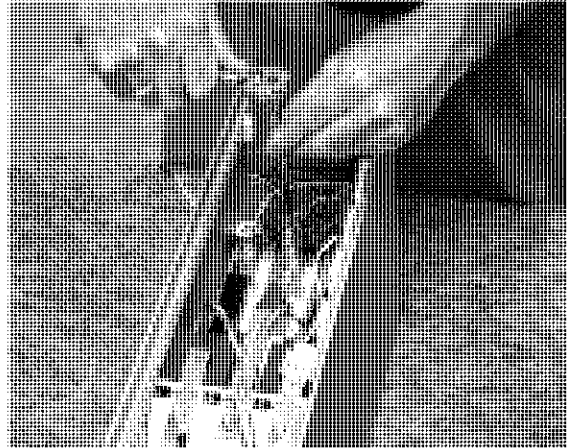

**Step 5.** Slide the bus bars (up or down) until clear of the screw securing the output bus bars (T1, T2, & T3) to the SCRs.

**Step 6.** Undo and remove the screws (1 per SCR) connecting the output bus bars (T1, T2 & T3) to each of the SCRs.

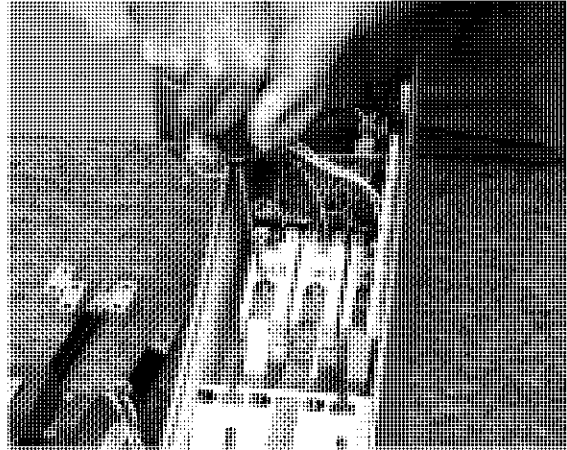

**Step 7.** Remove the screws (2) securing the bus bar support bracket to the lower plate.

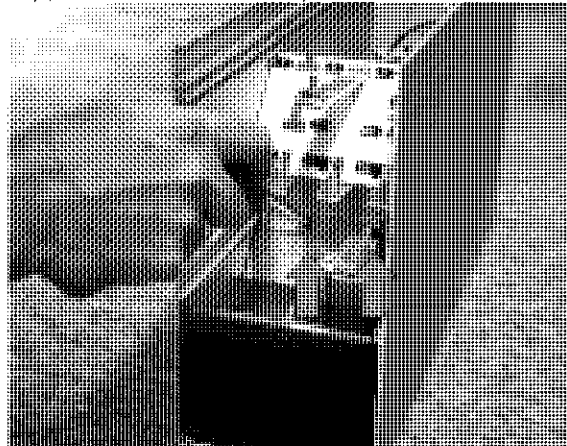

**Step 8.** Remove the left hand side panel by removing the screws (4) securing the side panel to the base plate.

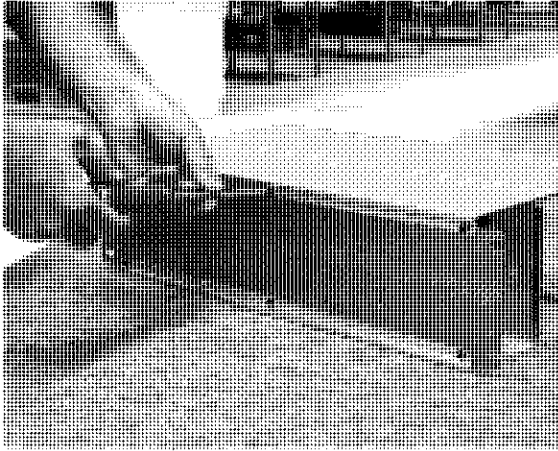

**Step 9.** Remove the bus bars, bus bar support bracket and insulation plate.

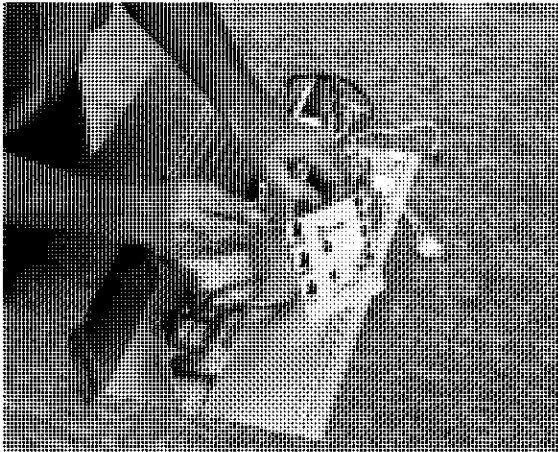

**Step 10.** Remove the screws (4) securing the fan bracket.

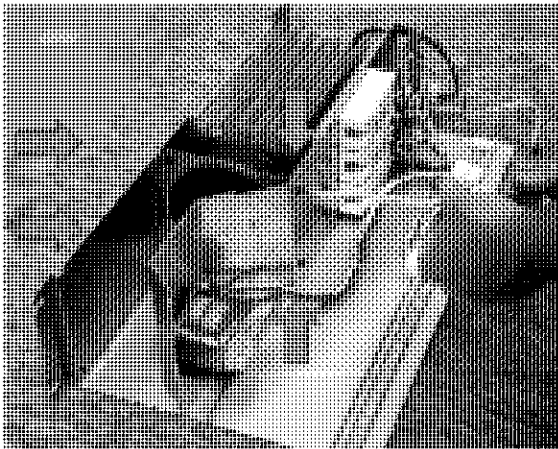

**Step 11.** Remove the fan bracket.

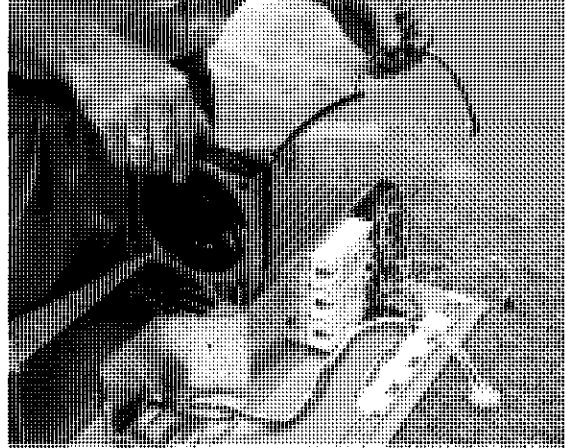

**Step 12.** Remove the fan from the fan bracket

**Step 13.** Cut the plug from the end of the fan wiring loom, leaving at least 75mm wire between the cut and the plug. Retain the plug, protective sleeve and grommet so that these can be fitted to the new fan wiring during re-assembly. Crimp terminals are supplied with the new fan for this purpose.

**Step 14.** Fit the new fan in reverse order.

**Cooling Fans: MCD3075 ~ MCD3110**

**Step 1.** Disassemble the MCD3000 as described for Identity Module replacement, Steps 1 to 3 (Page 18).

**Step 2.** Remove all remaining end caps & fan grills from the left side of the MCD3000.

**Step 3.** Undo the screws (2) securing the bus bar support bracket.

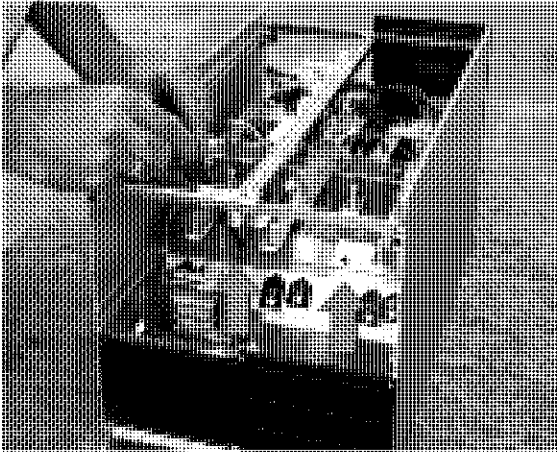

**Step 4.** Unclip the CT's and slide off the bus bar support bracket.

Note 1. For MCD3090 & 3110 this will also require the detachment of input bus bar I.R.

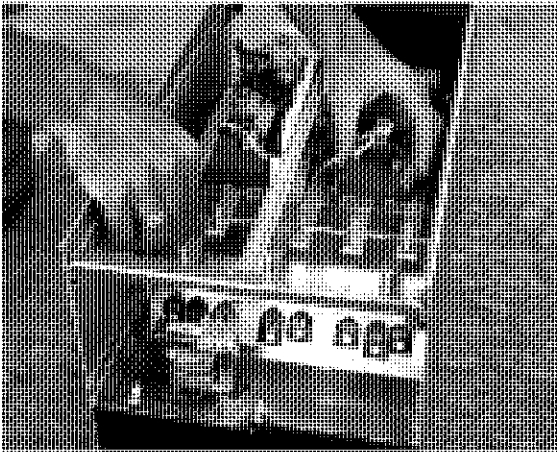

**Step 5.** Remove the insulation barrier located under the bus bar support bracket.

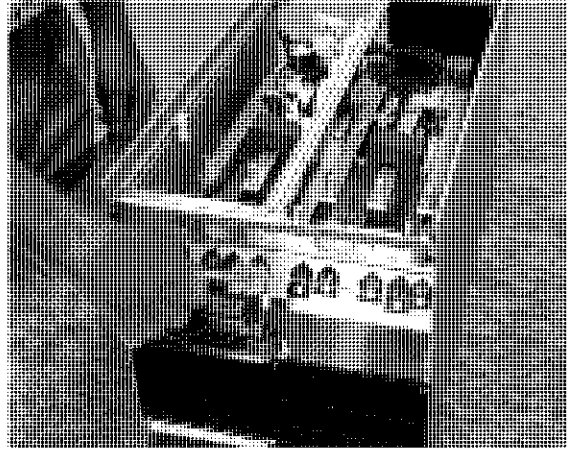

**Step 6.** Undo the screws (2) securing the left side panel to the top and bottom cross supports.

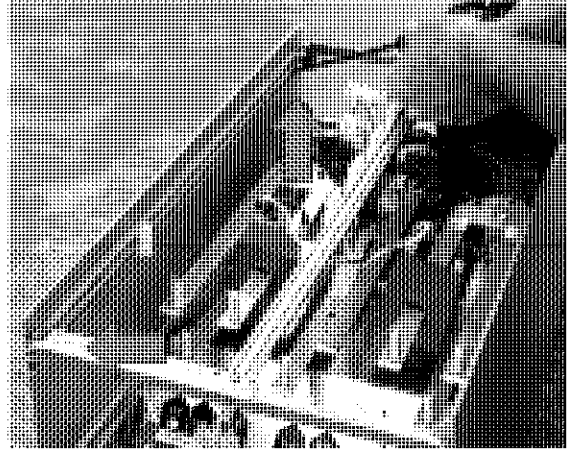

**Step 7.** Remove the left hand side panel by removing the screws (4) securing the side panel to the base plate.

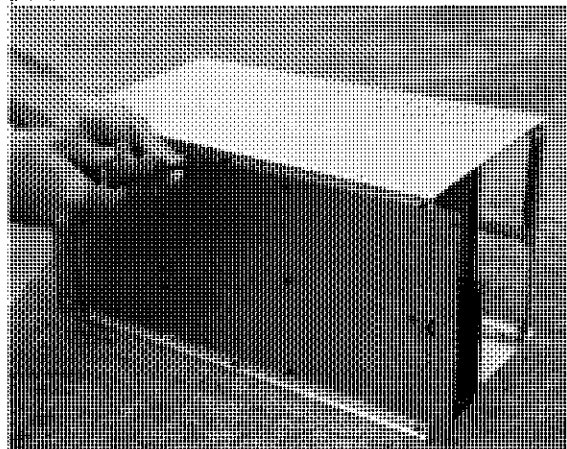

**Step 8.** Remove the screws (4) securing the fan bracket.

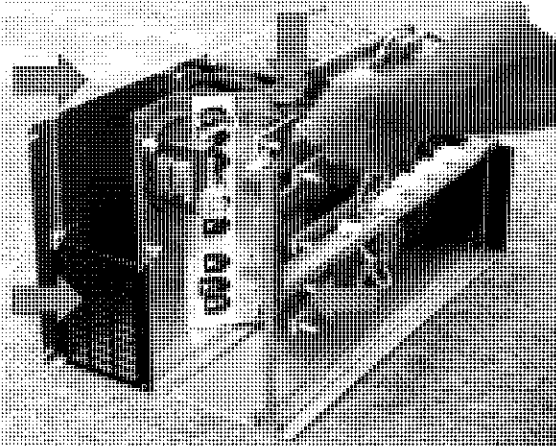

**Step 9.** Cut the plug from the end of the fan wiring loom, leaving at least 75mm wire between the cut and the plug. Retain the plug, protective sleeve and grommet so that these can be fitted to the new fan wiring during re-assembly. Crimp terminals are supplied with the new fan for this purpose.

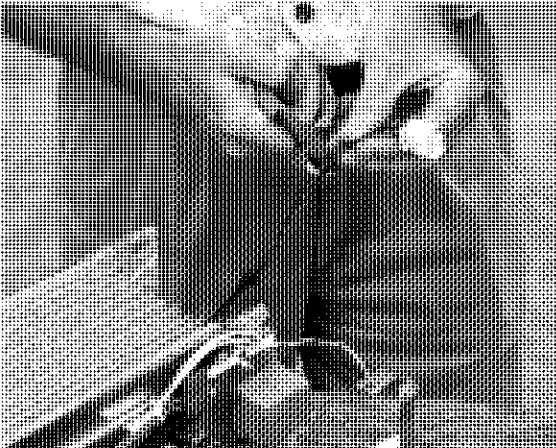

**Step 10.** Remove the fan bracket from the starter.

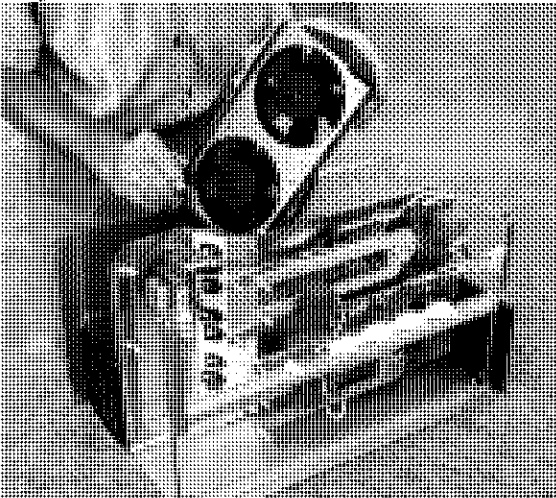

**Step 11.** Replace the damaged fan, ensuring that the protective sleeve is replaced over the fan wiring.

**Step 12.** Fit the fan bracket in reverse order.



### Cooling Fans: MCD3132

**Step 1.** Disassemble the MCD3000 as described for Identity Module replacement, Steps 1 to 3 (Page 18).

**Step 2.** Remove all remaining end caps & fan grills from the left side of the MCD3000.

**Step 3.** Undo the screws (2) securing the bus bar support bracket.

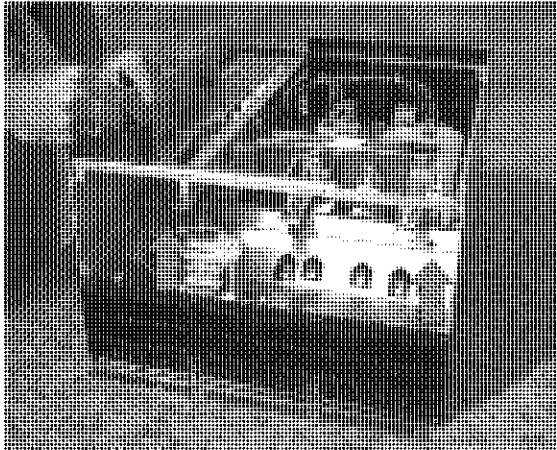

**Step 4.** Undo the screws securing the vertical support rail and slide the rail out of the way.

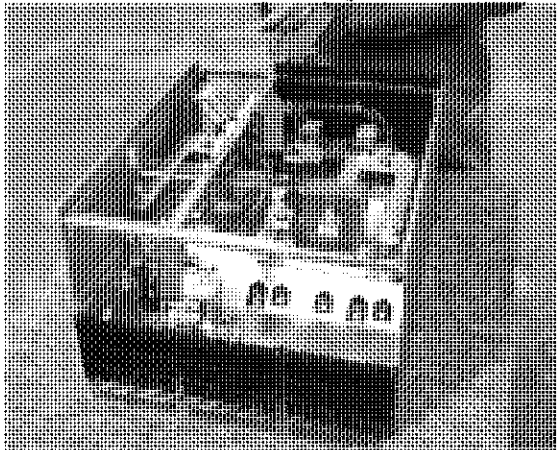

**Step 5.** Unclip the CTs and slide off the bus bar support bracket.

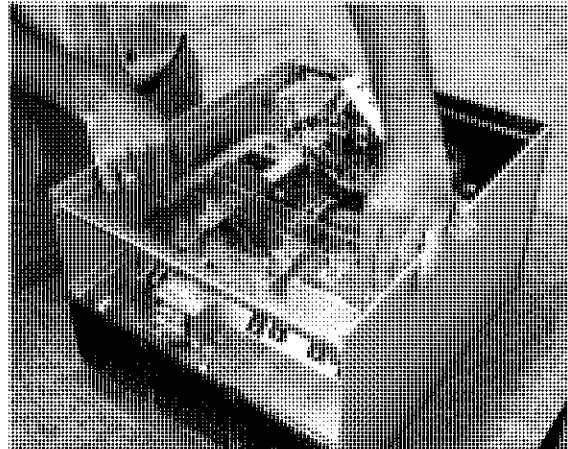

**Step 6.** Remove the insulation barrier located under the bus bar support bracket.

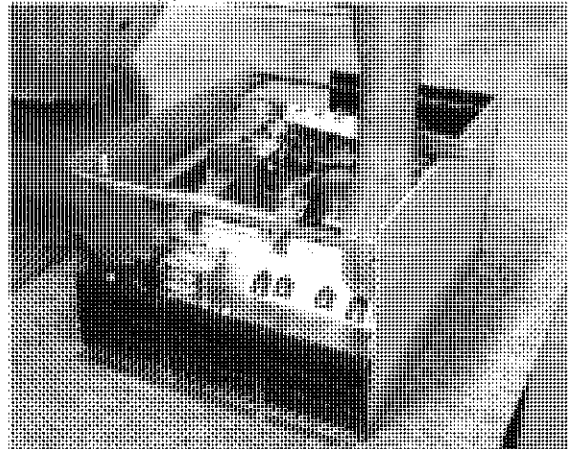

**Step 7.** Undo the screws (2) securing the left side panel to the top and bottom cross supports.

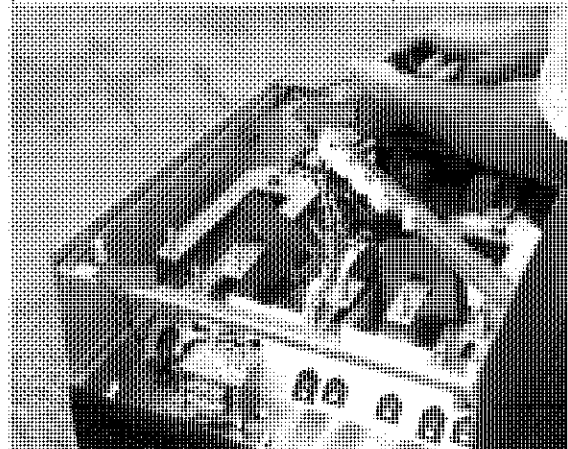

**Step 8.** Remove the left hand side panel by removing the screws (4) securing the side panel to the base plate.

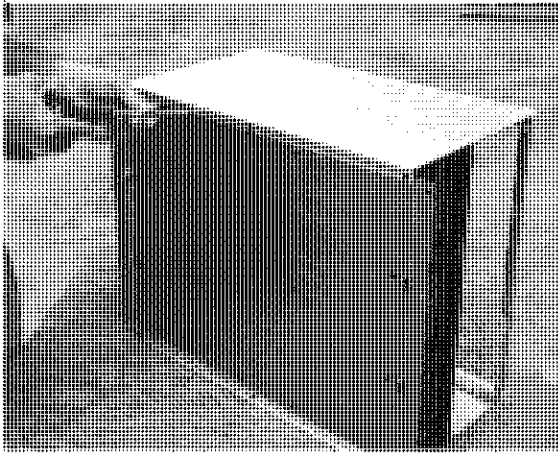

**Step 9.** Remove the screws (6) securing the fan bracket. This will also require the loosening of output bus bar T2.

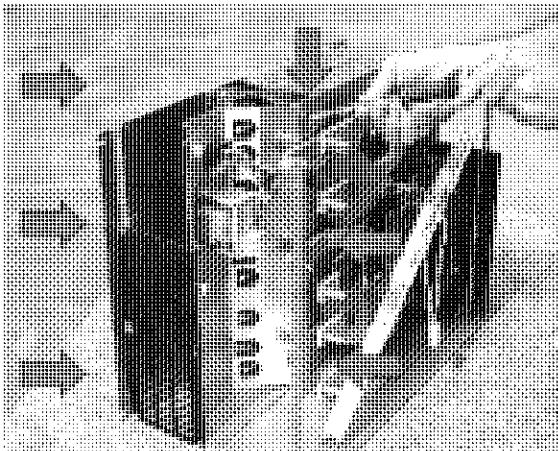

**Step 10.** Cut the crimp terminals (2) from the end of the fan wiring loom. New crimp terminals are supplied with the replacement fan for convenience.

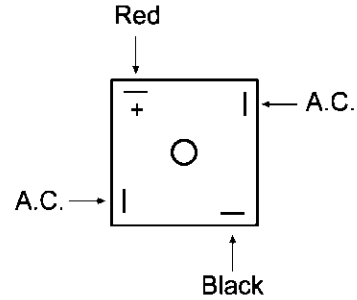
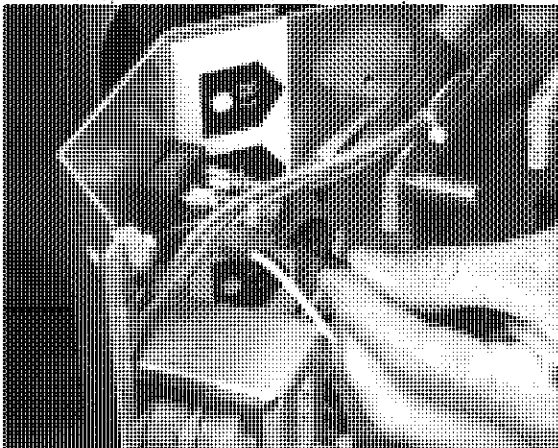

**Step 11.** Remove the fan bracket from the motor.

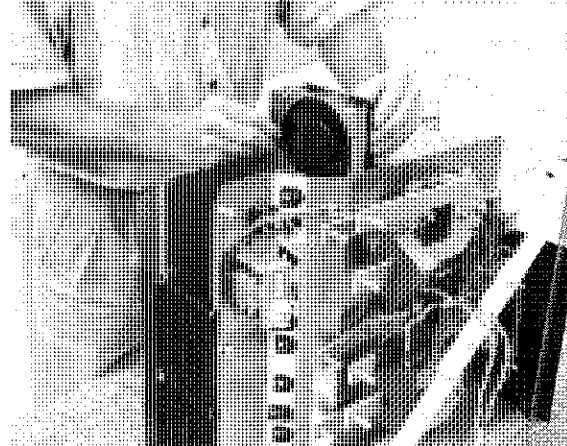

**Step 12.** Replace the damaged fan.

**Step 13.** Fit the fan bracket in reverse order.

**Cooling Fans: MCD3185 ~ MCD3800**

**Step 1.** Disassemble the MCD3000 as described for Power Assembly replacement, Steps 1 to 11 (Page 25)

**Step 2.** Undo the Power Assembly mounting screw (4) and remove the lower power assembly. For models MCD3600~3800 is will also require removal of the polyurethane fan insulation plate.

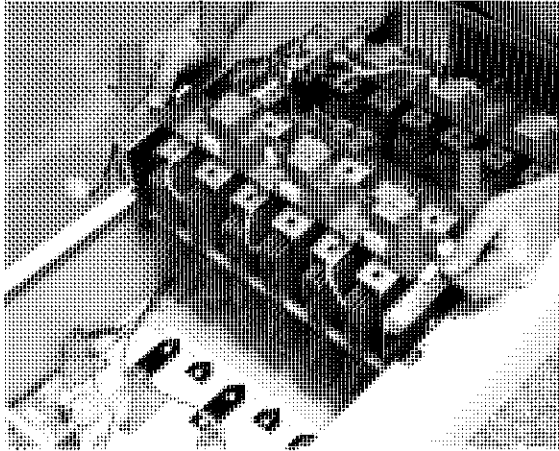

**Step 3.** Undo the Cooling Fan mounting assembly fixing screws (4) and remove the fan assembly.

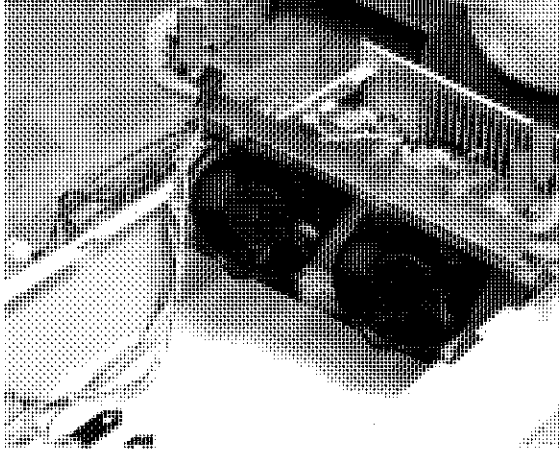

**Step 4.** Unplug the control supply from the cooling fan rectifier to free the assembly.

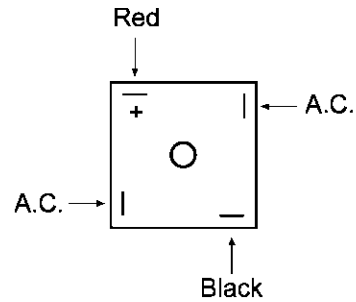
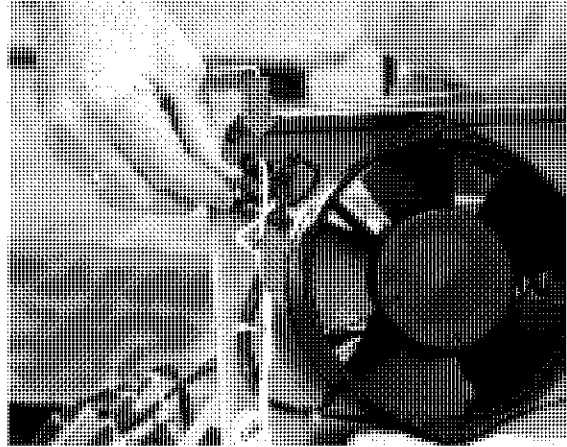

**Step 5.** Replace the damaged fan on the fan assembly and refit the Cooling Fan assembly in reverse order.

**Power Transformer: MCD3007 ~ MCD3055**

**Step 1.** Remove the lower front cover from the MCD3000.

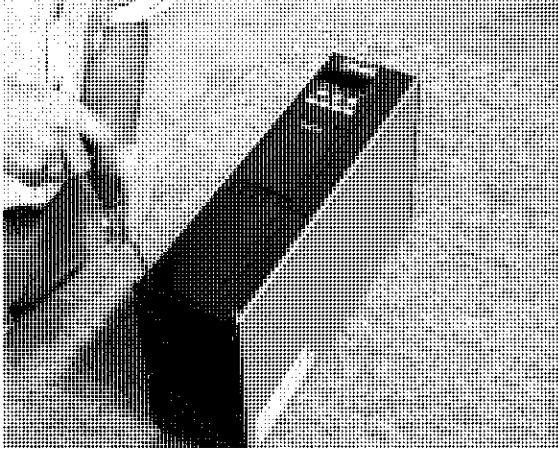

**Step 2.** Remove the lower gland plate from the MCD3000.

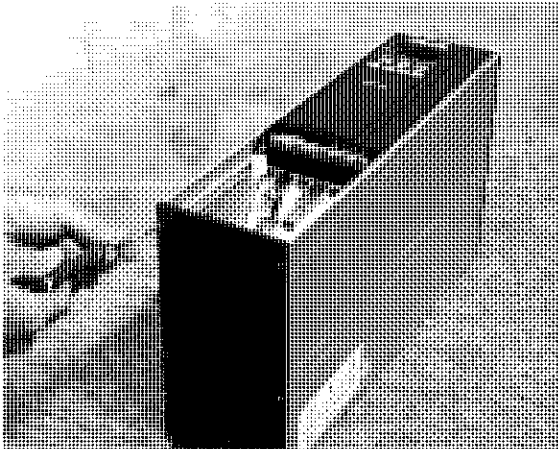

**Step 3.** Undo the screws (2) securing the power transformer and earth wire.



**Step 4.** Cut the wiring (MCD3007~3022 = orange, purple, orange, MCD3030~3055 = orange, purple, orange, white, white) running from the PT. Ensure sufficient wire length is left in the MCD3000 to enable connection of the replacement PT. Crimp terminals are supplied with the new PT for this connection.



**Step 5.** Fit the new PT in reverse order.

### Power Transformer: MCD3075 ~ MCD3110

**Step 1.** Remove the lower front cover from the MCD3000.



**Step 2.** Remove the lower gland plate from the MCD3000.

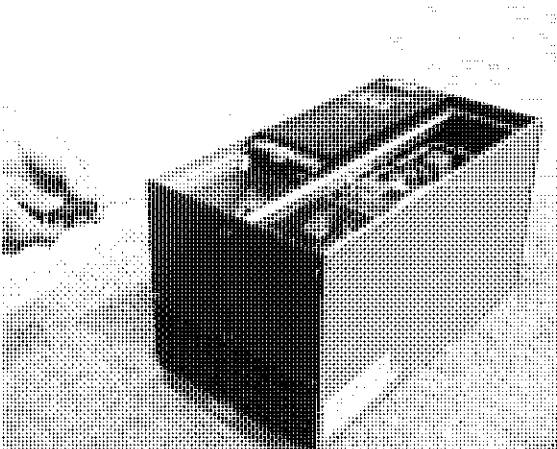

**Step 3.** Undo the screws (2) securing the power transformer and earth wire.

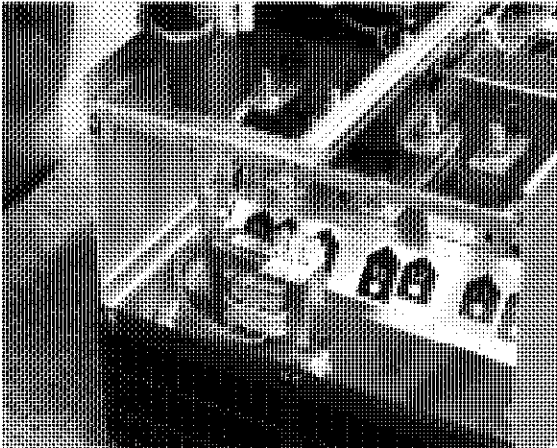

**Step 4.** Cut the wiring (orange, purple, orange, white, white) running from the PT. Ensure sufficient wire length is left in the MCD3000 to enable connection of the replacement PT. Crimp terminals are supplied with the new PT for this connection.



**Step 5.** Fit the new PT in reverse order.

**Power Transformer: MCD3132**

**Step 1.** Remove the lower front cover and aluminium front panels from the MCD3000.

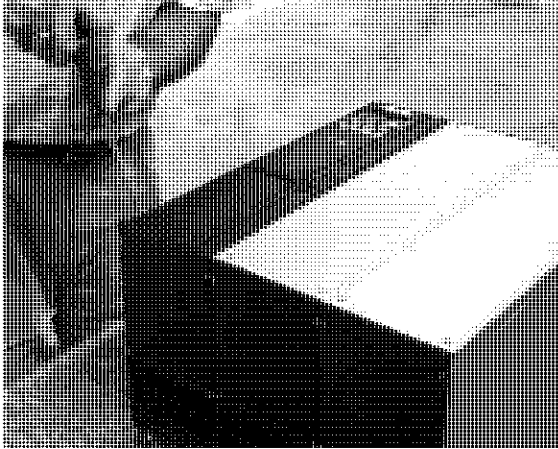

**Step 2.** Remove the lower gland plate from the MCD3000.

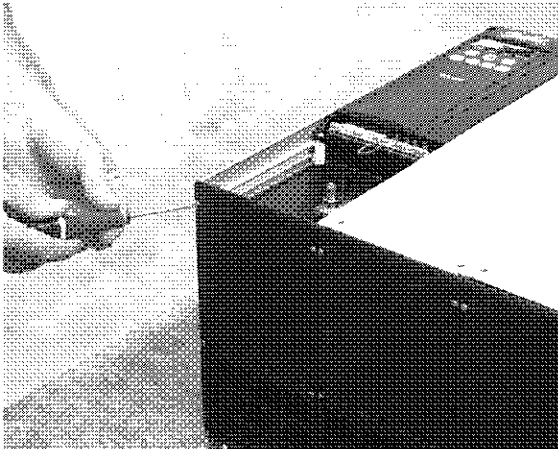

**Step 3.** Undo the screws (2) securing the power transformer and earth wire.

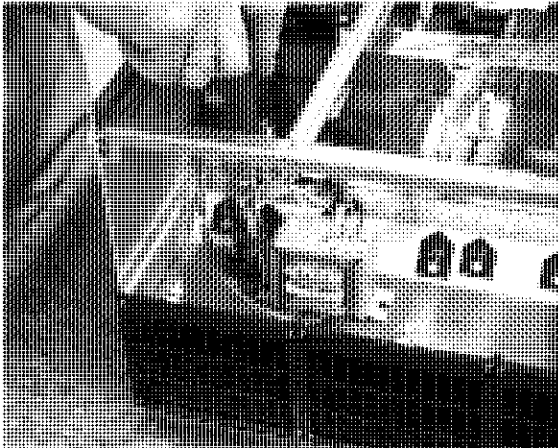

**Step 4.** Unplug the white wires (2) running from the PT to the fan supply rectifier.

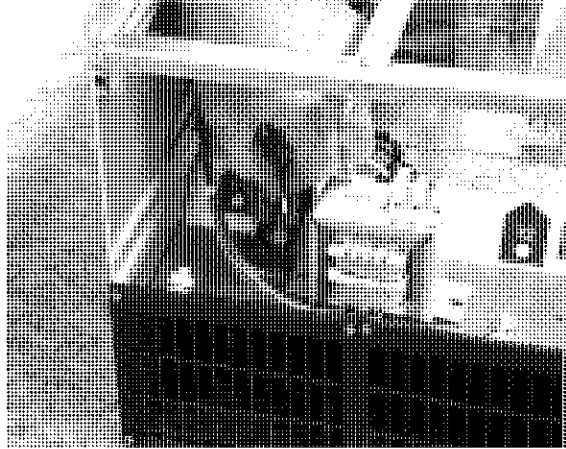

**Step 5.** Cut the wiring (orange, purple, orange) running from the PT. Ensure sufficient wire length is left in the MCD3000 to enable connection of the replacement PT. Crimp terminals are supplied with the new PT for this connection.

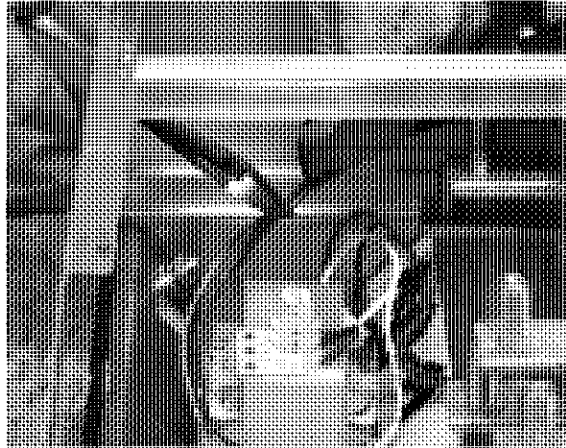

**Step 6.** Fit the new PT in reverse order.

**Power Transformer: MCD3185 ~ MCD3800**

**Step 1.** Undo fixing screws (4) and remove front cover.

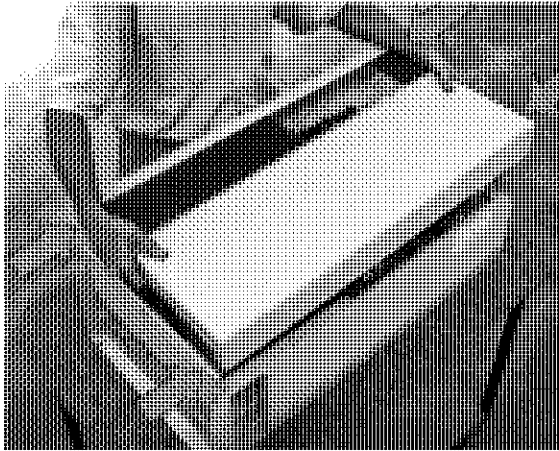

**Step 2.** Undo the screws (2) securing the power transformer and earth wire.

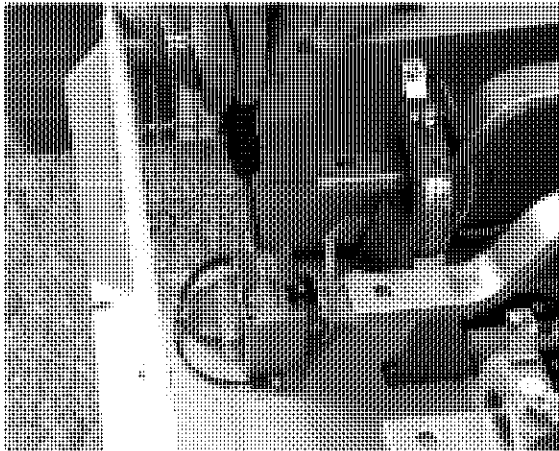

**Step 3.** Unplug the white wires (2) running from the PT to the fan supply recaller.



**Step 4.** Cut the wiring (orange, purple, orange) running from the PT. Ensure sufficient wire length is left in the MCD3000 to enable connection of the replacement PT. Crimp terminals are supplied with the new PT for this connection.

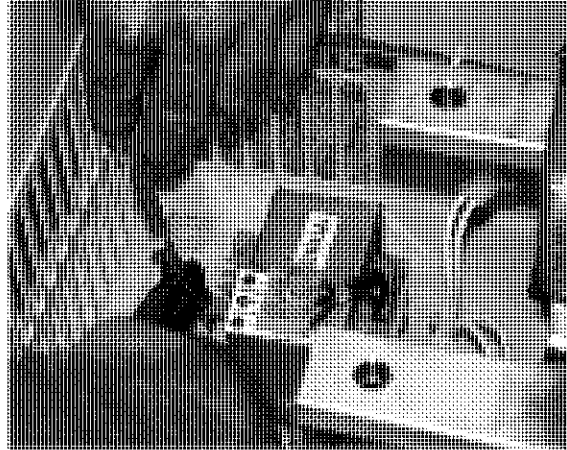

**Step 5.** Fit the new PT in reverse order.





### ■ Schematics

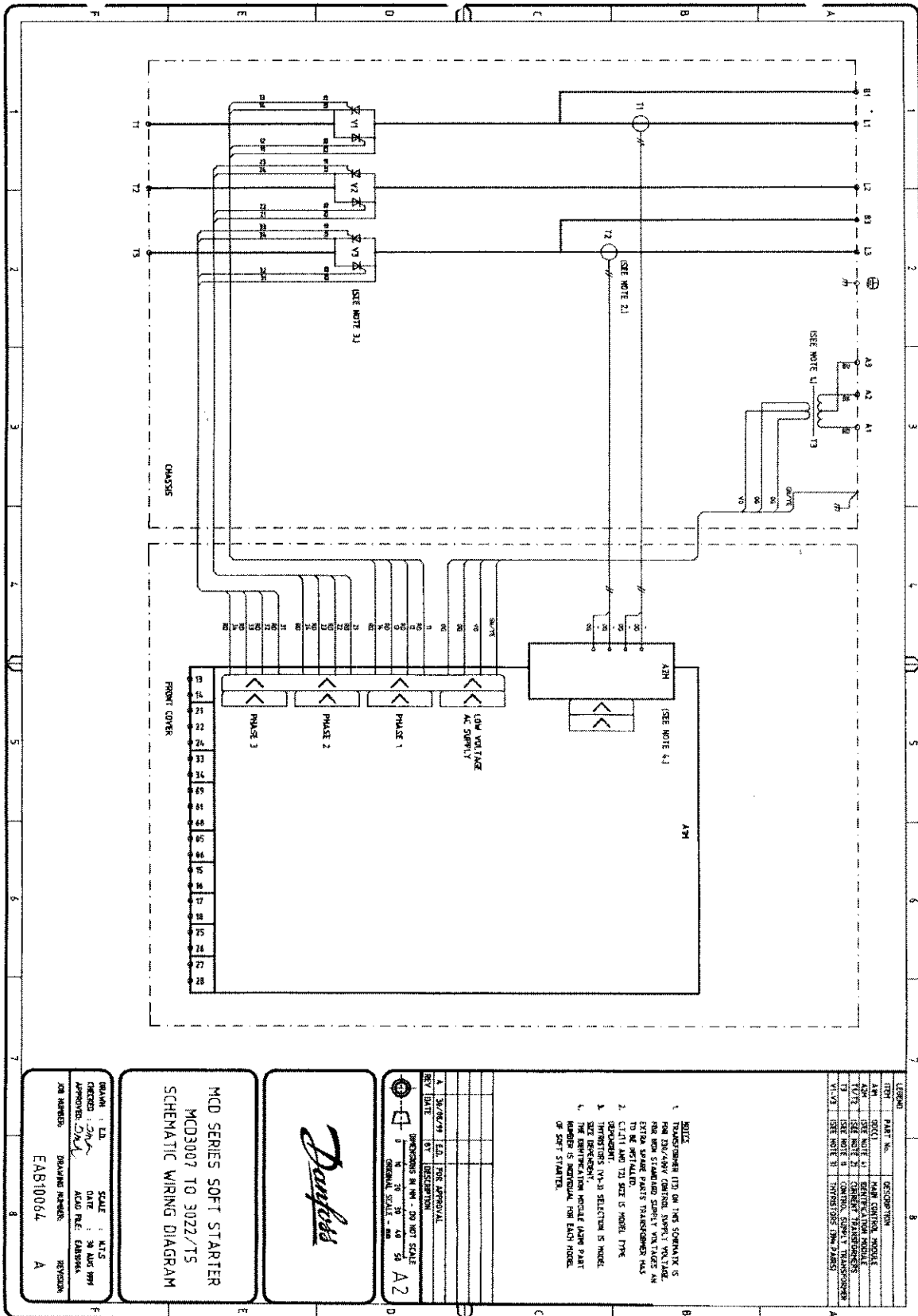

Schematics

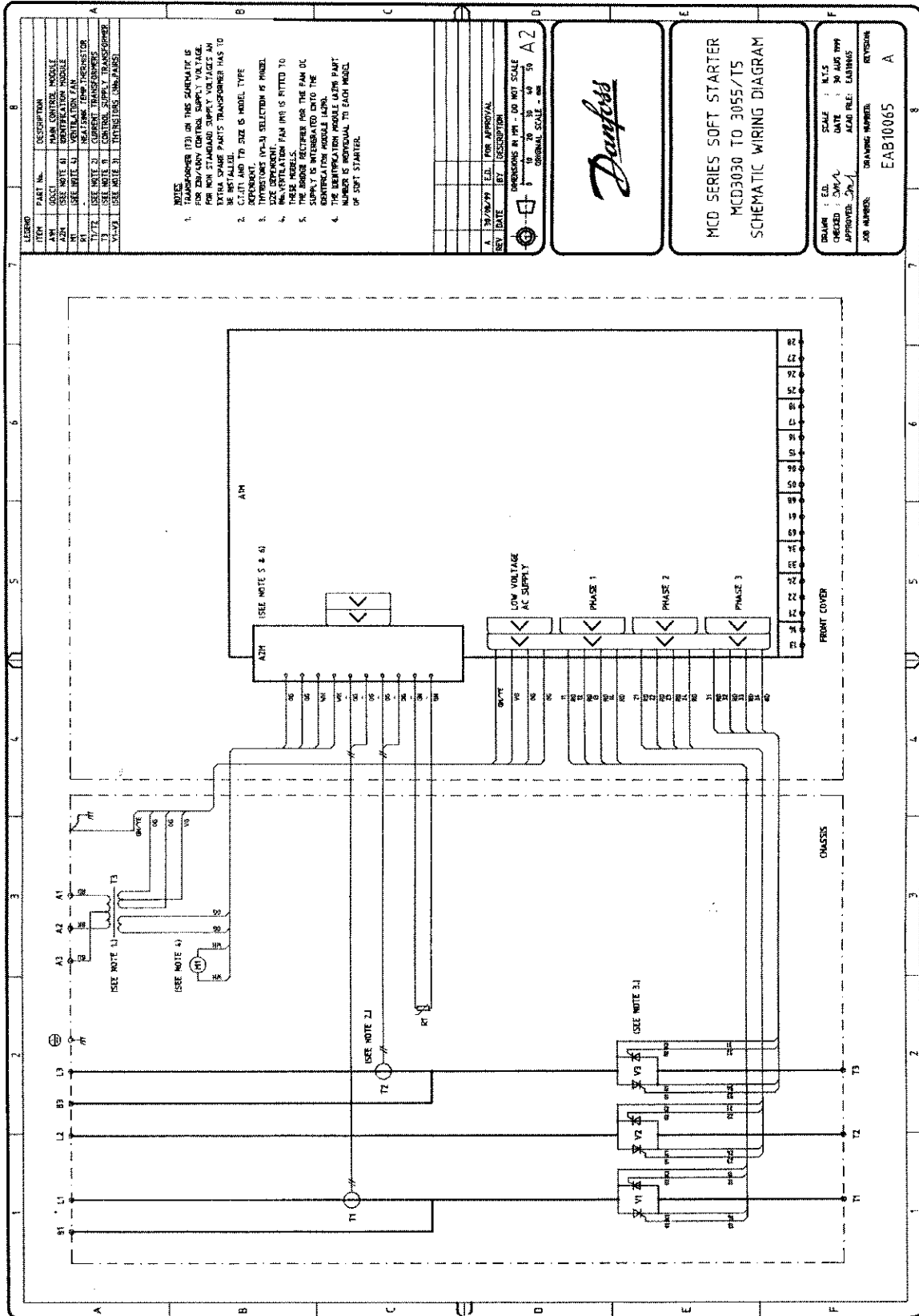

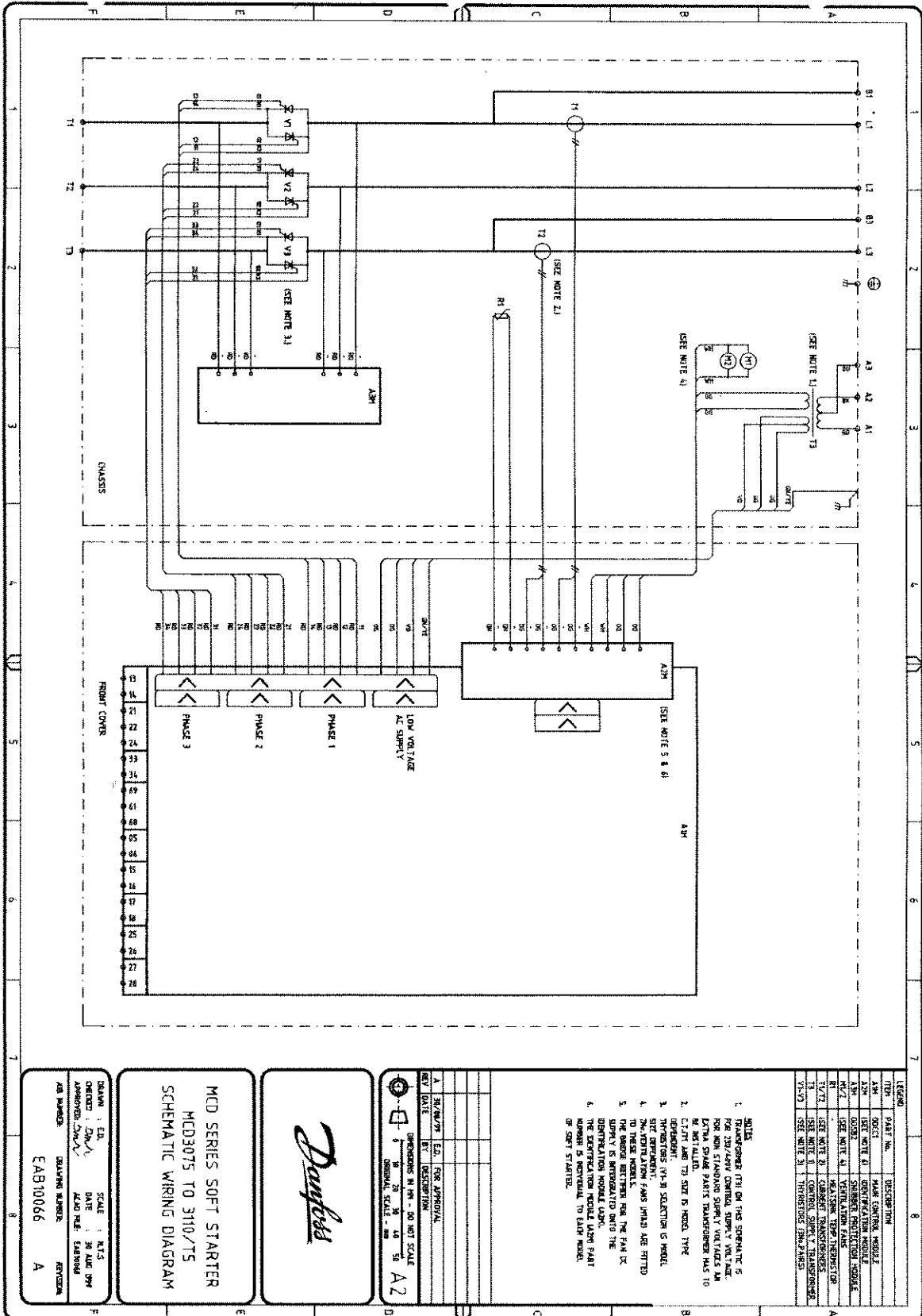

Schematics

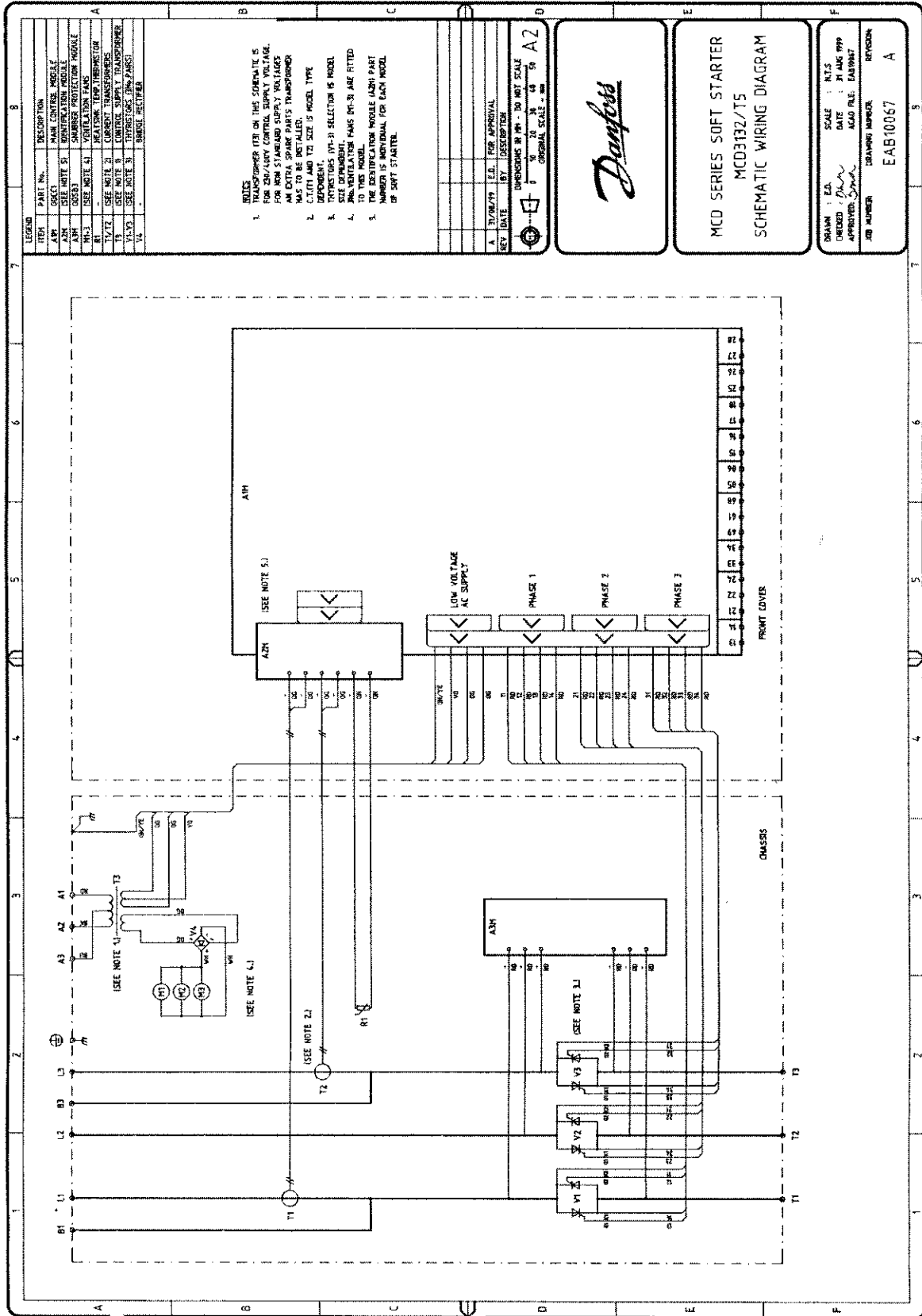

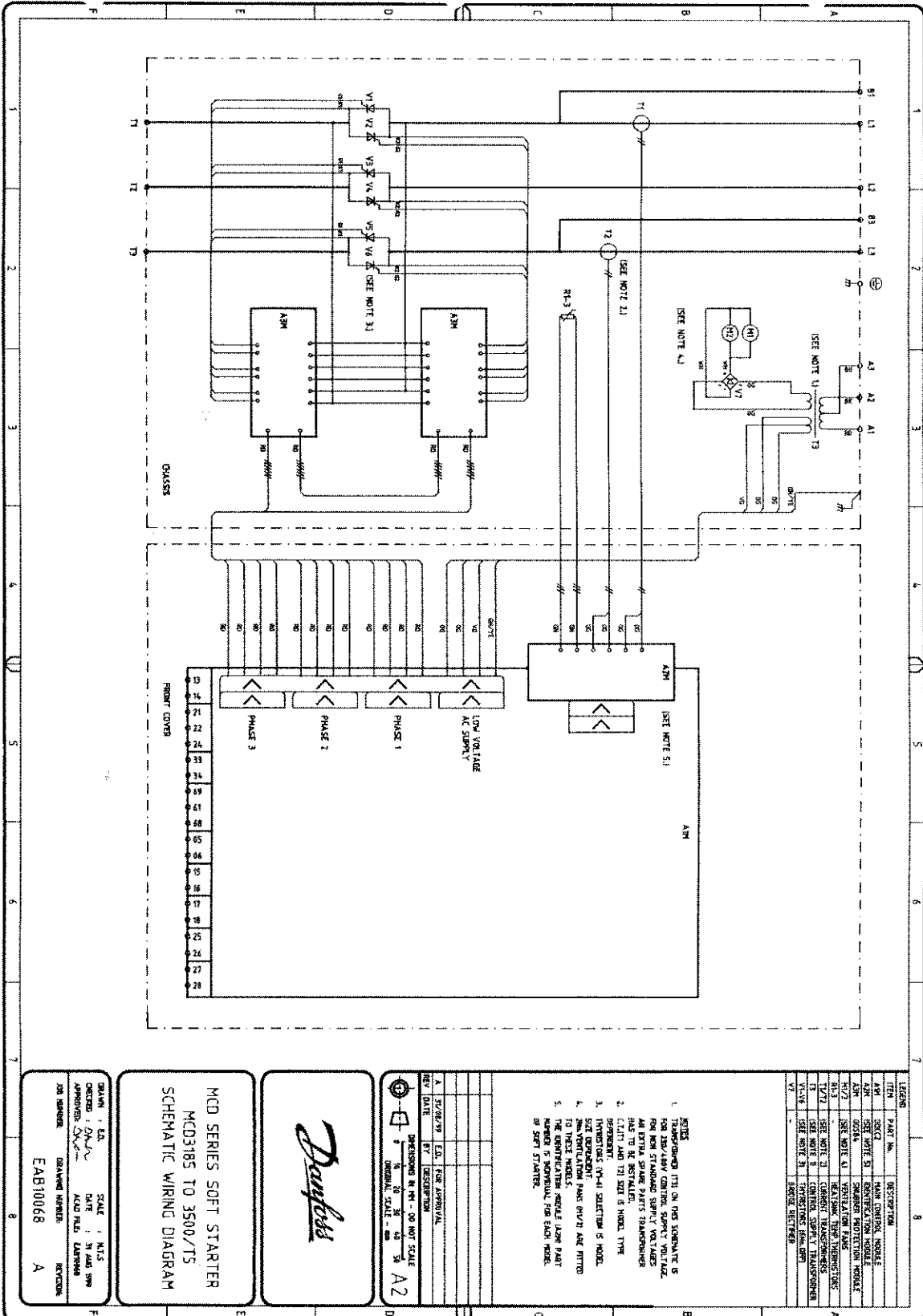

ITEM	PART No.	DESCRIPTION
APM	0000	MAIN CONTROL MODULE
APM	0001	CONTROL MODULE
APM	0002	CONTROL MODULE
APM	0003	CONTROL MODULE
APM	0004	CONTROL MODULE
APM	0005	CONTROL MODULE
APM	0006	CONTROL MODULE
APM	0007	CONTROL MODULE
APM	0008	CONTROL MODULE
APM	0009	CONTROL MODULE
APM	0010	CONTROL MODULE
APM	0011	CONTROL MODULE
APM	0012	CONTROL MODULE
APM	0013	CONTROL MODULE
APM	0014	CONTROL MODULE
APM	0015	CONTROL MODULE
APM	0016	CONTROL MODULE
APM	0017	CONTROL MODULE
APM	0018	CONTROL MODULE
APM	0019	CONTROL MODULE
APM	0020	CONTROL MODULE
APM	0021	CONTROL MODULE
APM	0022	CONTROL MODULE
APM	0023	CONTROL MODULE
APM	0024	CONTROL MODULE
APM	0025	CONTROL MODULE
APM	0026	CONTROL MODULE
APM	0027	CONTROL MODULE
APM	0028	CONTROL MODULE
APM	0029	CONTROL MODULE
APM	0030	CONTROL MODULE
APM	0031	CONTROL MODULE
APM	0032	CONTROL MODULE
APM	0033	CONTROL MODULE
APM	0034	CONTROL MODULE
APM	0035	CONTROL MODULE
APM	0036	CONTROL MODULE
APM	0037	CONTROL MODULE
APM	0038	CONTROL MODULE
APM	0039	CONTROL MODULE
APM	0040	CONTROL MODULE
APM	0041	CONTROL MODULE
APM	0042	CONTROL MODULE
APM	0043	CONTROL MODULE
APM	0044	CONTROL MODULE
APM	0045	CONTROL MODULE
APM	0046	CONTROL MODULE
APM	0047	CONTROL MODULE
APM	0048	CONTROL MODULE
APM	0049	CONTROL MODULE
APM	0050	CONTROL MODULE
APM	0051	CONTROL MODULE
APM	0052	CONTROL MODULE
APM	0053	CONTROL MODULE
APM	0054	CONTROL MODULE
APM	0055	CONTROL MODULE
APM	0056	CONTROL MODULE
APM	0057	CONTROL MODULE
APM	0058	CONTROL MODULE
APM	0059	CONTROL MODULE
APM	0060	CONTROL MODULE
APM	0061	CONTROL MODULE
APM	0062	CONTROL MODULE
APM	0063	CONTROL MODULE
APM	0064	CONTROL MODULE
APM	0065	CONTROL MODULE
APM	0066	CONTROL MODULE
APM	0067	CONTROL MODULE
APM	0068	CONTROL MODULE
APM	0069	CONTROL MODULE
APM	0070	CONTROL MODULE
APM	0071	CONTROL MODULE
APM	0072	CONTROL MODULE
APM	0073	CONTROL MODULE
APM	0074	CONTROL MODULE
APM	0075	CONTROL MODULE
APM	0076	CONTROL MODULE
APM	0077	CONTROL MODULE
APM	0078	CONTROL MODULE
APM	0079	CONTROL MODULE
APM	0080	CONTROL MODULE
APM	0081	CONTROL MODULE
APM	0082	CONTROL MODULE
APM	0083	CONTROL MODULE
APM	0084	CONTROL MODULE
APM	0085	CONTROL MODULE
APM	0086	CONTROL MODULE
APM	0087	CONTROL MODULE
APM	0088	CONTROL MODULE
APM	0089	CONTROL MODULE
APM	0090	CONTROL MODULE
APM	0091	CONTROL MODULE
APM	0092	CONTROL MODULE
APM	0093	CONTROL MODULE
APM	0094	CONTROL MODULE
APM	0095	CONTROL MODULE
APM	0096	CONTROL MODULE
APM	0097	CONTROL MODULE
APM	0098	CONTROL MODULE
APM	0099	CONTROL MODULE
APM	0100	CONTROL MODULE

NOTE: REFER TO THE MCD SERIES SOFT STARTER IS FOR THE/LOW CONTROL SUPPLY VOLTAGE. FOR NON STANDARD SUPPLY VOLTAGES, AN EXTRA SPARE PARTS TRANSFORMER HAS TO BE ORDERED.

- CONTROL AND TBI SIZE IS MODEL TYPE
- THE TRANSFORMER ON-AI SELECTION IS MODEL
- SEE DIMENSION
- THE VENTILATION PANS (H/V) ARE FITTED TO THESE MODELS. REPAIR FROM PART LIST IS AVAILABLE FOR EACH MODEL OF SOFT STARTER.

REV	DATE	BY	DESCRIPTION	ED.	FOR APPROVAL
A	25/08/99				

DIMENSIONS IN MM - DO NOT SCALE  
 ORIGINAL SCALE - A2



MCD SERIES SOFT STARTER  
 MCD3185 TO 3500/TS  
 SCHEMATIC WIRING DIAGRAM

DRAWN : E.A.	SCALE : MTS
CHECKED : D.M.	DATE : 31 MAR 99
APPROVED : S.K.	ACLD FILE: LKRW004
JOB NUMBER : EAB10068	DRAWING NUMBER : A
	EXTENSION :

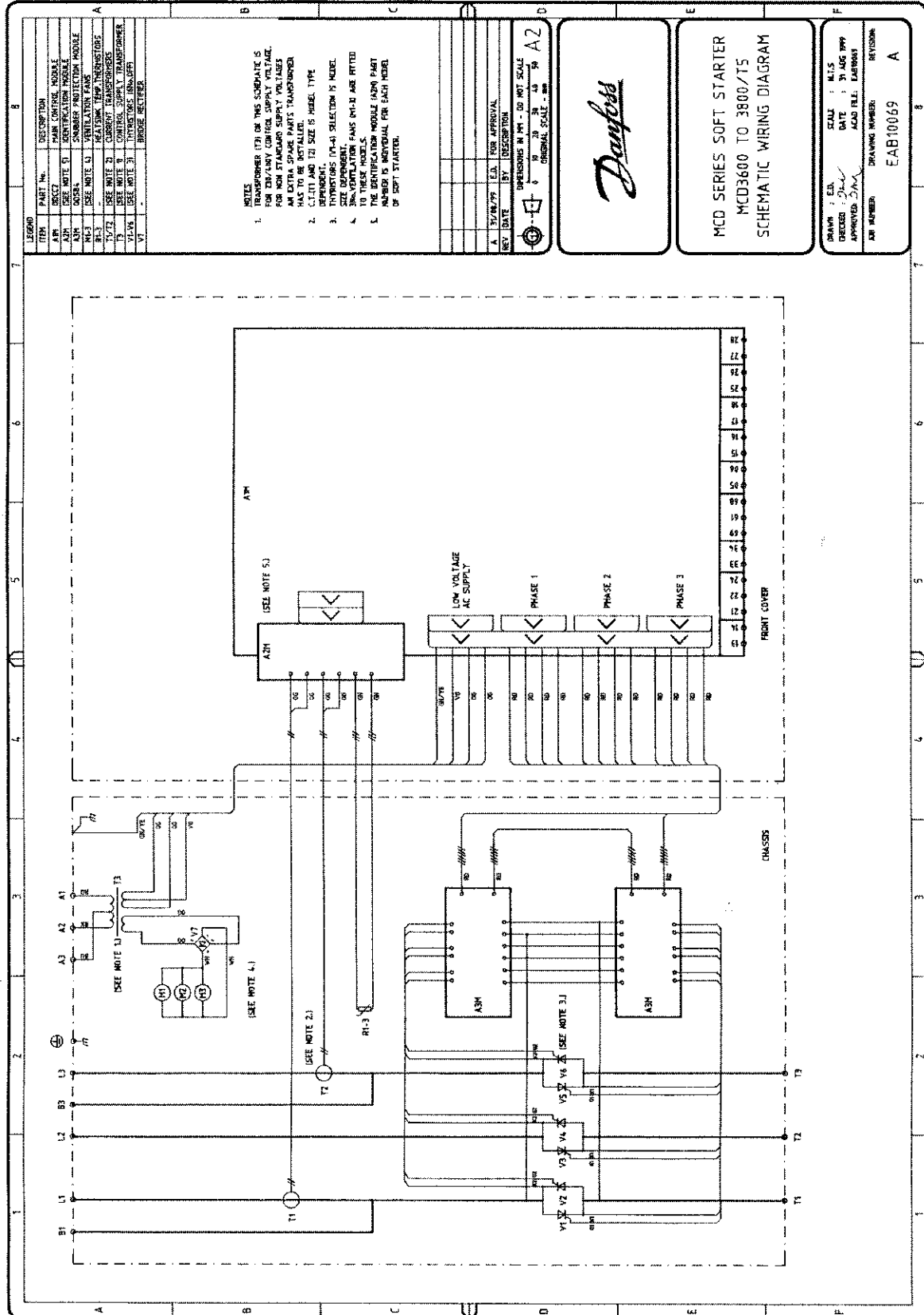

MCD SERIES SOFT STARTER  
 MCD3600 TO 3800/T5  
 SCHEMATIC WIRING DIAGRAM  
 DRAWN : E.D.  
 CHECKED : [Signature]  
 APPROVED : [Signature]  
 AIR NUMBER : EAB10069  
 SCALE : 1:1 N.T.S.  
 DATE : 21 AUG 1999  
 ACAD TELL : EAB0800  
 REVISION :

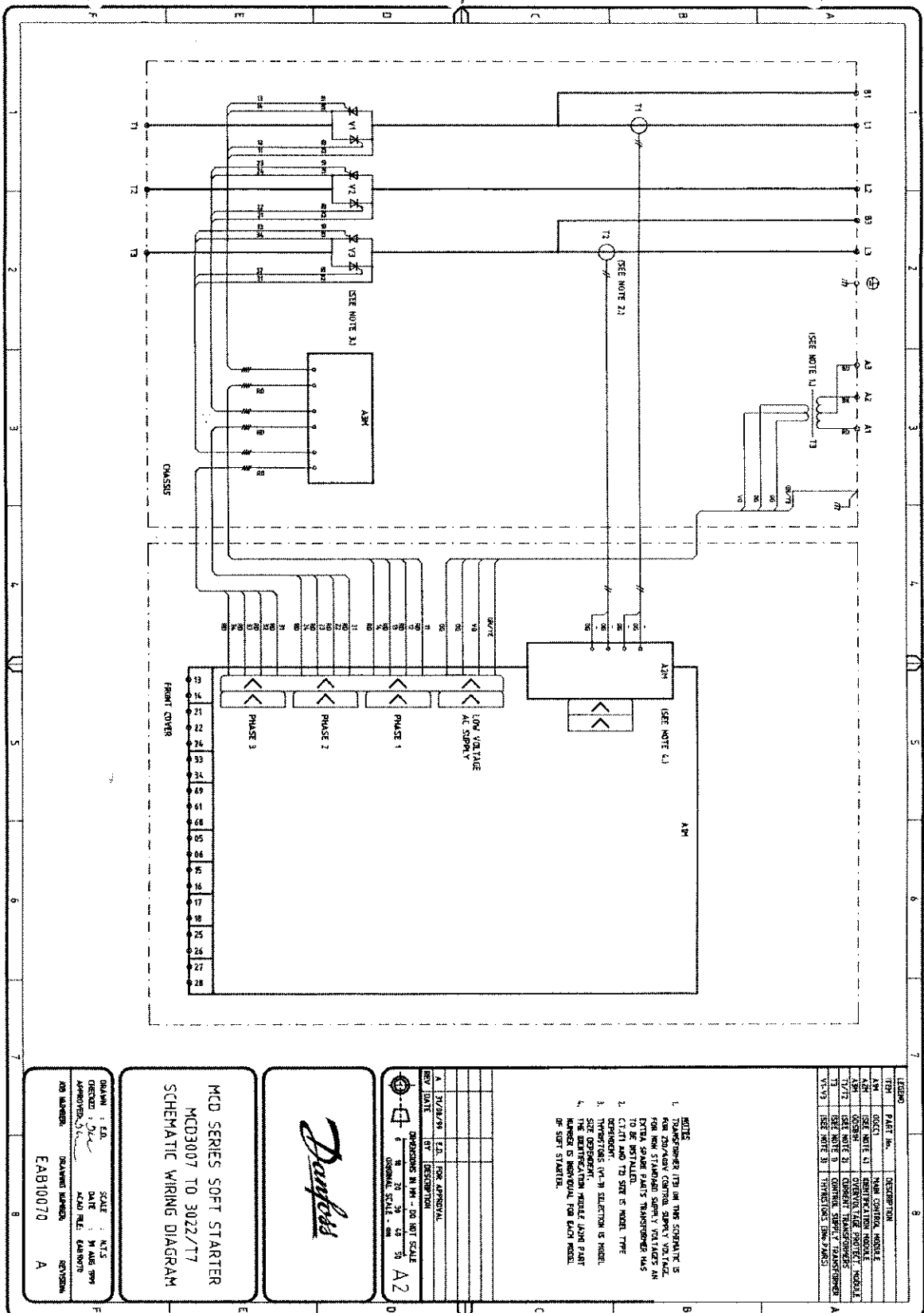

Schematics

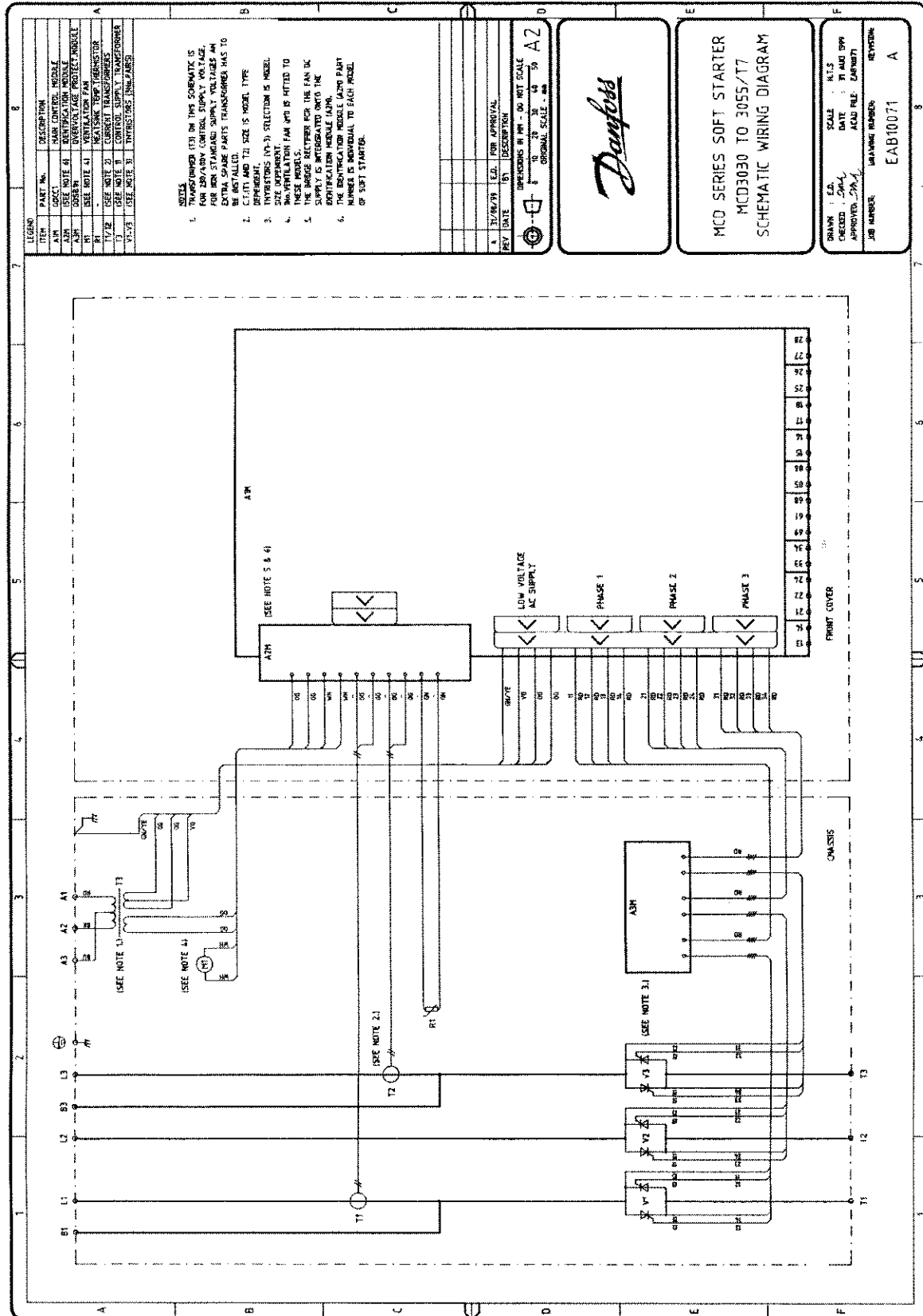



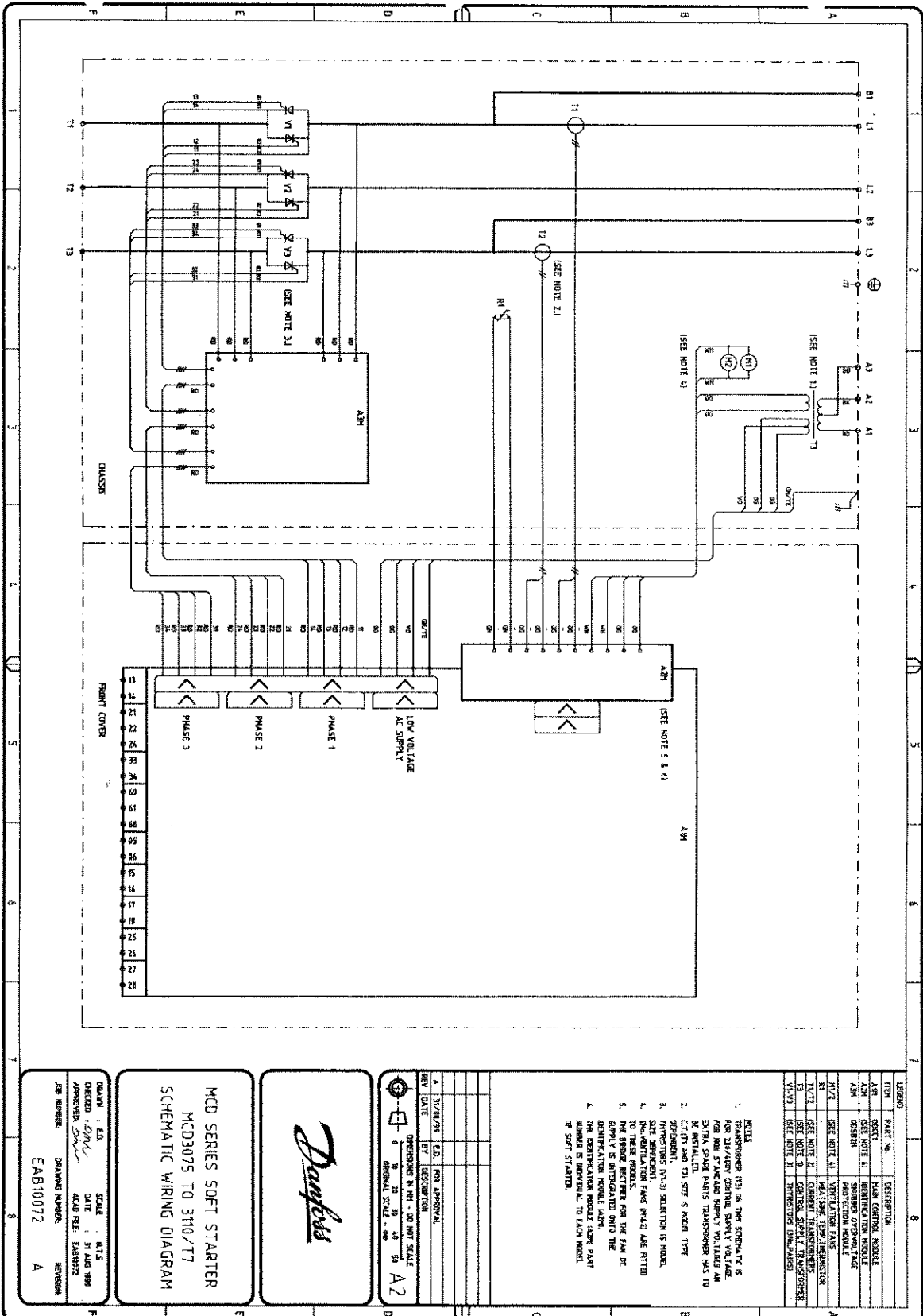

Schematics

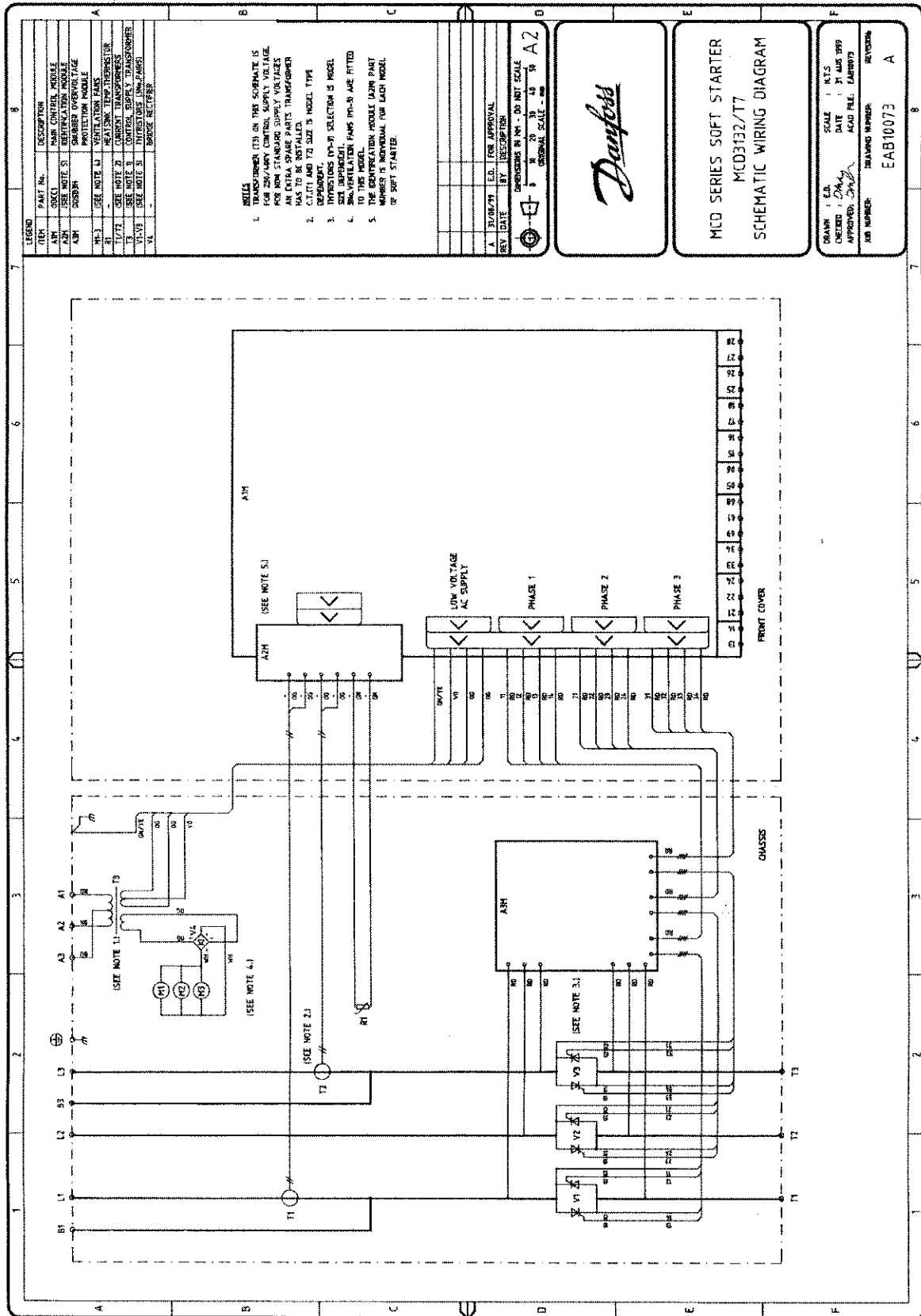

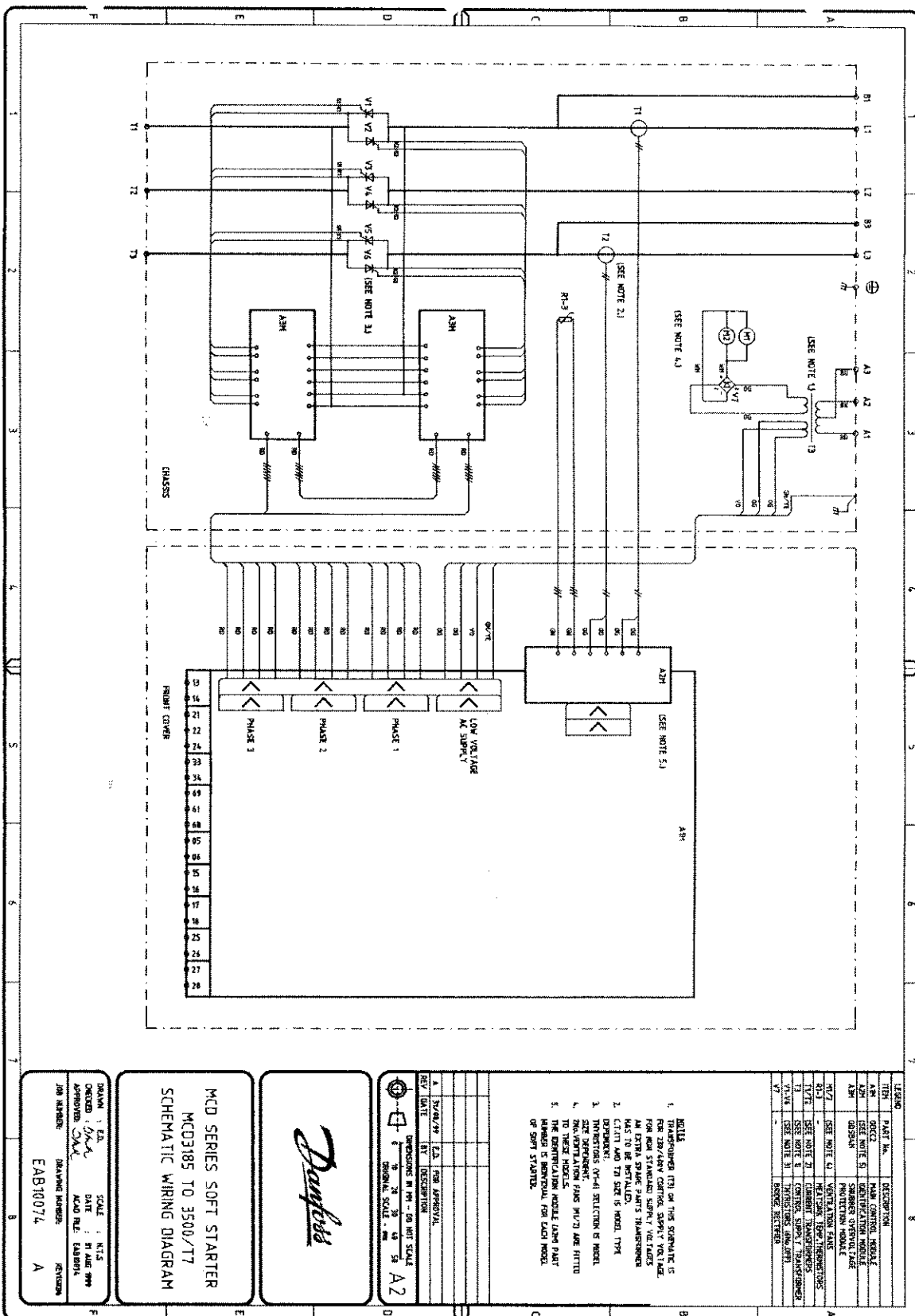

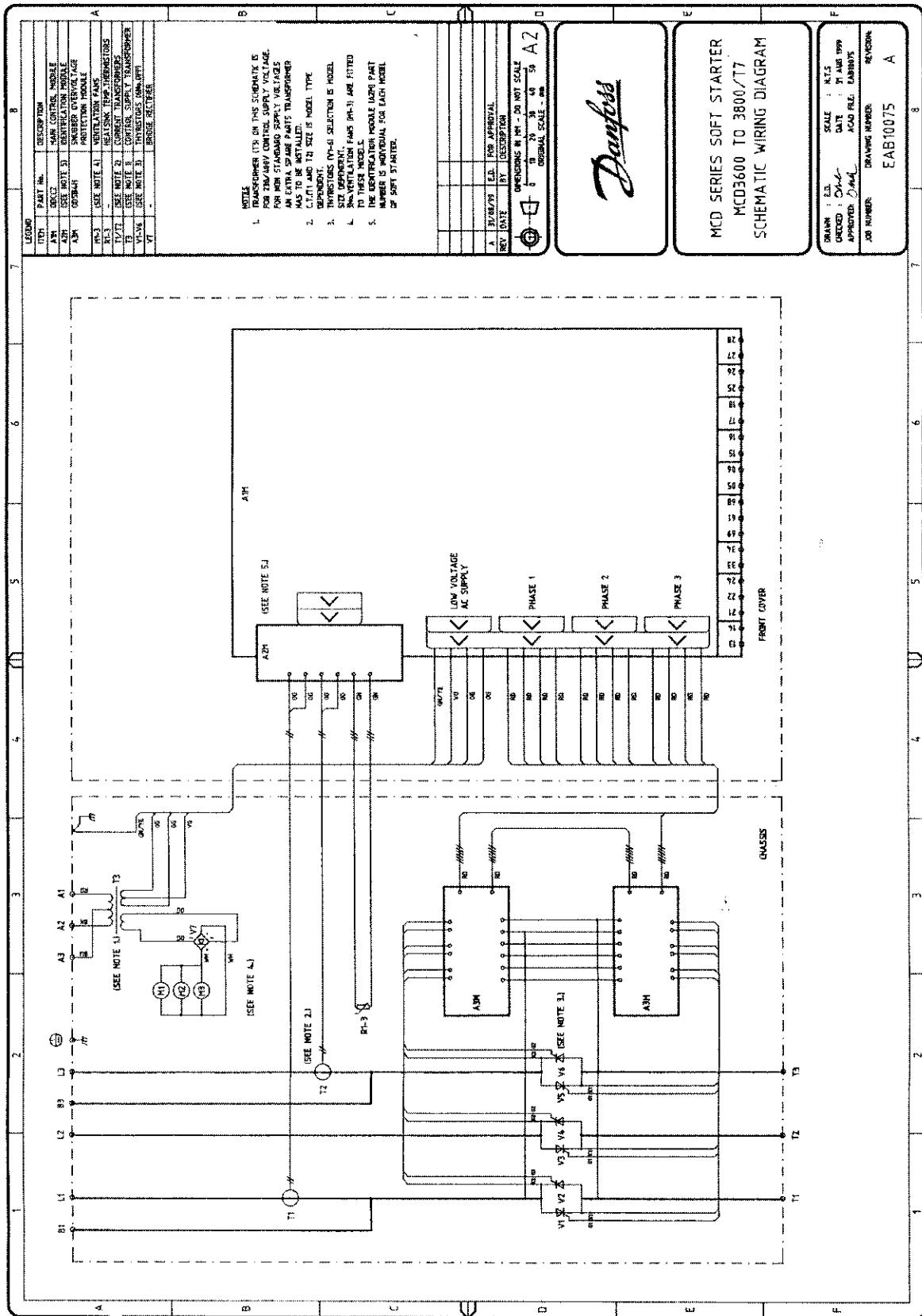

**■ Appendix**
**Typical Causes of SCR Damage**
**Overview**

The reliability of the modern SCRs as used in the MCD3000 Series soft starters is such that failures attributable to faulty manufacture are almost nil. SCR damage is almost always caused by external influences. Often these influences can be identified but in other cases the identification may prove difficult or impossible because the damaging event was temporary in nature.

**Typical causes of SCR damage**

SCR damage is generally caused by one of three mechanisms, overcurrent, overvoltage or overtemperature. Before replacing damaged SCRs it is important to identify the cause of damage if at all possible. The following list details some of the common problems.

**Overcurrent**

- Cable fault on output of soft starter.
- Motor fault.
- Start current and/or start time exceeds the soft starter ratings.

**Overvoltage**

- Power supply transient or surge.
- Lightning strike on power supply.
- Motor fault.
- Loose connection in power circuit, before or after the starter.
- Power factor correction connected to the output of the soft starter.
- Over corrected bulk power factor correction on a lightly loaded system causing severe ringing voltages.

**Overtemperature**

- Blocked heatsinks or restricted ventilation.
- Faulty cooling fans.
- Inadequate ventilation.
- Excessive ambient temperatures.

**Protecting SCRs**

The SCRs used in modern soft starters are rugged and provide reliable operation in most industrial environments without the need for additional protection. However the potential for SCR damage can be reduced by use of semiconductor fuses and/or line contactors.

**Semiconductor fuses:** Use of semiconductor fuses reduces the potential for SCR damage caused by short circuits on the output of the starter. Note that protection systems such as circuit breakers or HRC fuses do not operate quickly enough to protect SCRs from short circuits.

**Line contactors:** SCRs are most vulnerable to damage caused by overvoltage when they are in the off state and have voltage applied to their input terminal. In this condition the SCR is blocking the full line voltage. Use of a line contactor to remove voltage from the SCR input when the starter is in the off state eliminates the chance of SCR damage due to overvoltage. Note that when the soft starter is operating and the SCRs are fully conducting the SCR is not blocking line voltage and is thus immune to damage caused by voltage fluctuations.

### Output Relay Compatibility

#### Overview

The MCD3000 soft starter has three programmable output relays (Output A, B, C). These PCB mount relays are often used for line or bypass contactor control.

Recent advances in contactor design have led to many manufacturers using electronic contactor coils. Initially these coils may appear to meet the specifications of the PCB mount relays. However, in some instances these electronic contactor coils have a high initial inrush current due to the internal switch mode power supply circuitry. This can have a damaging effect on the PCB mount relays if the contactor coil is switched directly.

#### Solution

Before using an MCD3000 soft starter PCB mount output relay for direct switching of an electronic contactor coil, consult the contactor manufacturer/supplier to see if this is advisable. Certain contactor manufacturers (eg, Klochner Moeller) state that you cannot use PCB mount relays for direct switching of their electronic contactor coils. If this is the case, there are two solutions:

1. Use an MCD3000 soft starter output relay to control a slave relay. This slave relay can then be used to directly switch the electronic contactor coil circuit.

2. Some contactor brands have a volt free electronic input (low voltage/low current). If this is available, the MCD3000 output relay can be wired directly into this input for contactor control.

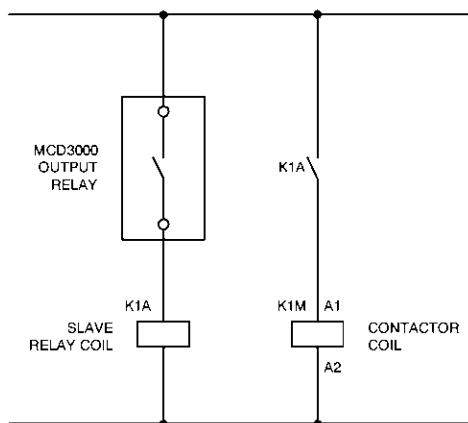
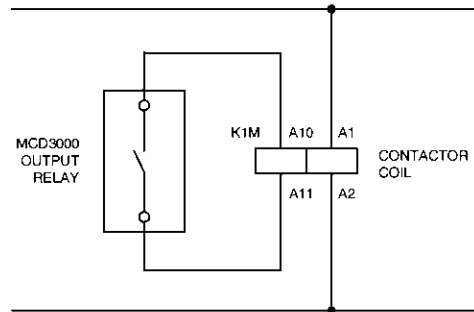

## Remote Control Input failure

### Overview

The MCD3000 soft starter can be operated in Local or Remote mode. The operational mode is selected using the LOCAL/REMOTE pushbutton on the front control panel of the MCD3000.

In local mode the REMOTE LED is not illuminated and the soft starter is operated using the Start, Stop, and Reset operational pushbuttons on the MCD3000 front control panel.

In Remote mode the REMOTE LED is illuminated and the soft starter is operated using the four remote control inputs. When a remote control input is closed using an external contact, the associated remote control input status LED is illuminated.

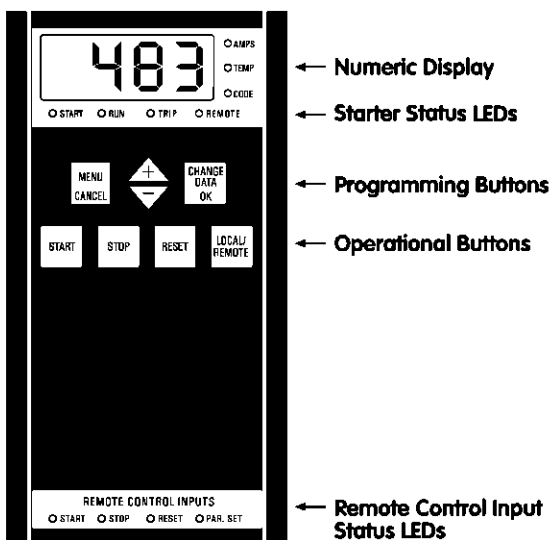

### Cause of Remote Control Input failure

External contacts used for operating the remote control inputs must be low current/low voltage types (gold flash or similar). These inputs are internally powered by 24VDC and must only be operated by external volt free contacts.



Application of external voltages to the remote control inputs will cause equipment damage and necessitate replacement of the Main Control Module.

### Testing for Remote Control Input failure

When the MCD3000 soft starter is operated in Remote mode, the associated remote control input status LED will illuminate when the input is closed using an external contact. If the status LED does not illuminate, damage has occurred to the remote control input on the Main Control Module.

This damage is caused by applying external voltage, either directly or indirectly (eg, induced voltage from lightning strike) to the remote control input.



### ATTENTION

Damage to the control inputs caused by application of external voltages is not covered by warranty.





## MCD 3000 Softstarter



## Service Manual

**VLT**<sup>®</sup> frequency converters **BAUER** powered motors

Danfoss can accept no responsibility for possible errors in catalogues, brochures and other printed material. Danfoss reserves the right to alter its products without notice. This also applies to products already on order provided that such alterations can be made without consequential changes being necessary in specifications already agreed. All trademarks in this material are property of the respective companies. Danfoss and the Danfoss logotype are trademarks of Danfoss A/S. All rights reserved.

